

Installation & Maintenance Guide

PROTECTOSEAL SERIES NO. 30 TANK BLANKETING VALVE

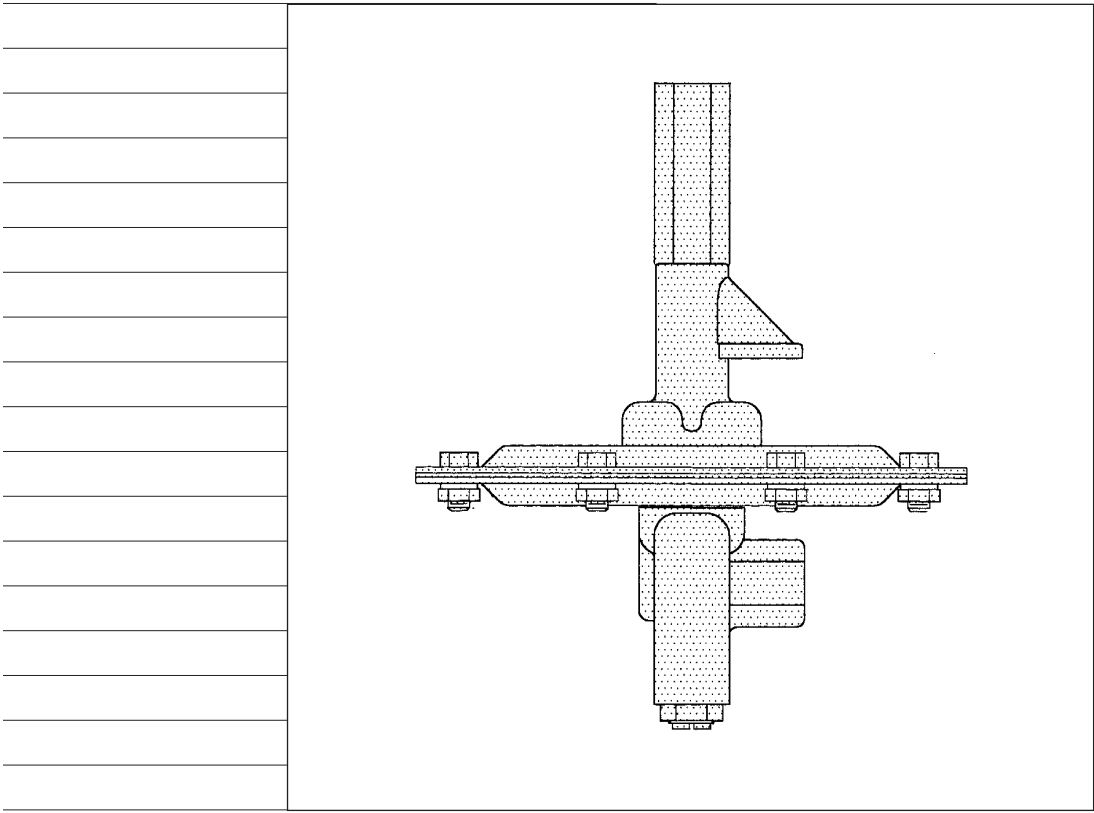



225 Foster Ave., Bensenville, IL 60106-1690
P 630.595.0800 F 630.595.8059
info@protectoseal.com www.protectoseal.com

Definition of Terms

Some of the terms used in this manual are defined below:

Conservation Vent: A device which is connected to a storage tank and regulates the pressure therein. Conservation vents may provide pressure relief, vacuum relief, or both. Pallets move in direct response to tank pressure allowing flow out of or into the tank. Pallet movement may be controlled by weight-loading, spring-loading, or a pilot valve.

Deadband: The total pressure difference between the blanketing valve opening pressure (or set point) and resealing pressure.

Diaphragm Chamber: The portion of the valve which contains the sense diaphragm.

Emergency Vent: A conservation vent which provides additional pressure relief to accommodate extraordinary conditions such as fire exposure to a tank or full-open failure of a blanketing valve.

Flow Plug: A fitting installed at the valve inlet port to reduce the flow of gas through the valve.

Inlet Port: The connection to the blanketing valve coming from the gas supply line.

Outlet Port: The connection to the blanketing valve leading to the storage tank.

Poppet: The component in the valve which can move open from a normally seated position to allow flow through the valve.

Poppet Spring: The spring which biases the poppet towards the seated position.

Purge: A very low flow of supply gas directed past the sense line and/or the outlet in order to keep corrosive vapors away from the blanketing valve.

Sense Chamber: The space below the diaphragm chamber to which the pressure from the sense line is directed. The pressure in the sense chamber controls the opening and closing of the blanketing valve.

Sense Diaphragm: A thin, non-metallic disc in the diaphragm chamber which flexes in response to changes in tank pressure acting upon it.

Sense Line: A line running from the storage tank to the sense port of the blanketing valve. It feeds tank pressure to the underside of the sense diaphragm.

Sense Port: The connection to the blanketing valve coming from the sense line.

Set Point: The tank pressure (positive or negative) at which the blanketing valve opens.

Soft Goods: The elastomeric components of the blanketing valve including the O-rings, gaskets and diaphragm.

Stop: A bolt connected to the sense diaphragm which contacts the poppet to move it in response to movement of the sense diaphragm.

Viton® and Kalrez® are registered Trademarks of E.I. DuPont de Nemours & Co., Inc.
Chemraz® is a registered Trademark of Green, Tweed & Co., Inc.

INSTALLATION

Placement

The blanketing valve should be placed on top of the storage tank with its outlet connected via a short run of pipe to the top of the tank. A second line runs from the sense port of the valve to a separate connection on the tank. A line coming from the blanketing gas supply source connects to the valve inlet. The blanketing valve must be positioned so that the inlet line is horizontal and the outlet line points downward. Installation requires connecting the blanketing valve to three lines as shown below in Fig. 1.

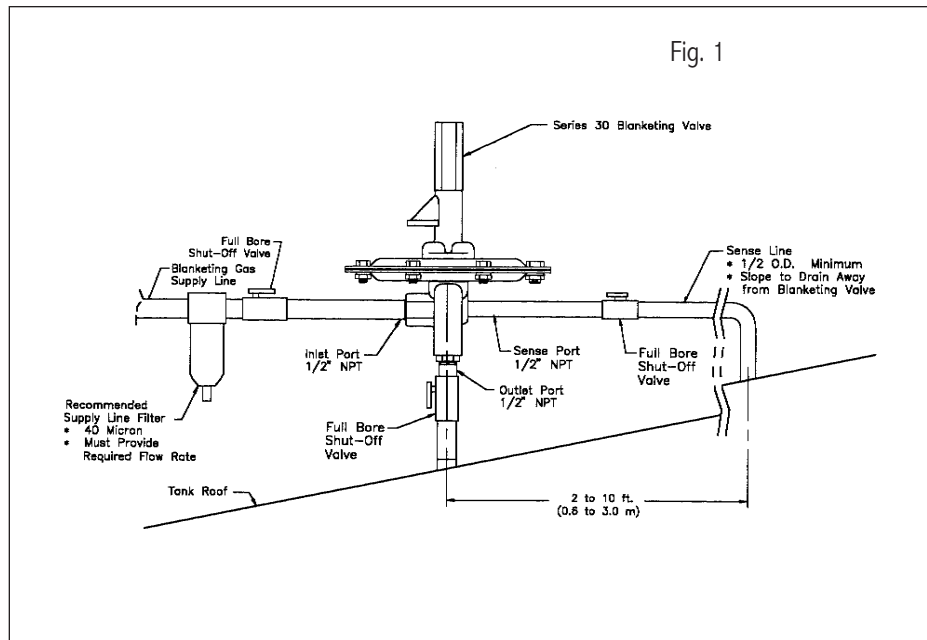

All three lines connecting to the valve should have full bore shut-off valves so that the unit can be isolated and depressurized for maintenance. The use of pipe unions at each connection will facilitate installation and removal of the blanketing valve. FEP tape should be applied to all pipe thread connections. However, be careful in applying it so that the tape cannot get loose inside and potentially clog the blanketing valve. Further details regarding the three lines follow:

■ **SUPPLY LINE:** The piping leading to the blanketing valve inlet should be the same pipe size as the inlet connection. This line should incorporate a full bore shut-off valve to enable isolation of the valve from the pressure supply during maintenance. The line should also include an in-line filter. A 40 micron filter element is recommended. The filter flow capacity must be higher than the required flow through the blanketing valve.

■ **OUTLET LINE:** The piping from the valve outlet should be the same size as the outlet connection. This line should also incorporate a full bore-shut-off valve to enable isolation of the blanketing valve from the tank during maintenance. A short, straight pipe run from the valve outlet to the top of the storage tank is recommended. An extended length of pipe from the blanketing valve to the tank could lead to delayed closing of the valve and thus overpressurization of the tank.

■ **SENSE LINE:** The sense line should also include a full bore valve to enable isolation of the blanketing valve from the tank during maintenance. The horizontal run from the sense port should be angled slightly down away from the valve to ensure that any

Installation, Start-up & Shut-Down

- Placement 1
- Start-Up 2
- Shut-Down 3

Maintenance

- Purpose & Frequency..... 3
- Leakage Check..... 3
- Disassembly & Inspection 3
- Reassembly 5
- Reinstallation & System Check 5
- Set Point Adjustment 6

Accessories

- Filter..... 13
- Pressure Gauges 14
- Integral Purge Accessories..... 14
- Field Test Accessories 17

Troubleshooting

Problem -

- #1 The blanketing valve does not open at all 23
- #2 The blanketing valve flows full open without resealing 23
- #3 The blanketing valve leaks continuously..... 24
- #4 The blanketing valve opens above or below the set point..... 24
- #5 The pressure vent or other pressure relief device opens 24
before the blanketing valve closes
- #6 The vacuum vent or other vacuum relief device opens 25
- #7 The blanketing valve cycles, repeatedly opening and 25
closing

Figures

- #1 Installation 1
- #2 Recommended Minimum Sense Line I.D. Based on Length 2
- #3 Bolt Tightening Pattern..... 5
- #4 Blanketing Valve..... 8
- #5 Diaphragm Assembly 9
- #6 Main Valve Assembly 10
- #7 Recommended Test Set-Up..... 12
- #8 Pilot Filter..... 13
- #9 Pressure Gauges 14
- #10 Integral Purge System 15
- #11 Higher Pressure Set Point Field Test Kit 21
- #12 Low Pressure Set Point Field Test Kit 22

condensate could not drain into the valve. $\frac{1}{2}$ " O.D. tubing or larger should be used to ensure that there is not a pressure drop from the tank to the valve. This size line is also needed so that the high pressure supply gas which leaks into the sense chamber while the valve is open is able to dissipate into the tank so as not to affect closing of the blanketing valve.

The sense line connection to the tank should be far enough from the outlet line connection to ensure that a static pressure is sensed. On the other hand, the line should not be so long as to lead to a pressure drop in the line. A range of 2 to 10 feet from the outlet line connection is recommended. If a longer sense line is necessary, then the size of the tubing or pipe should be increased according to offset pressure drop effects, see Fig. 2.

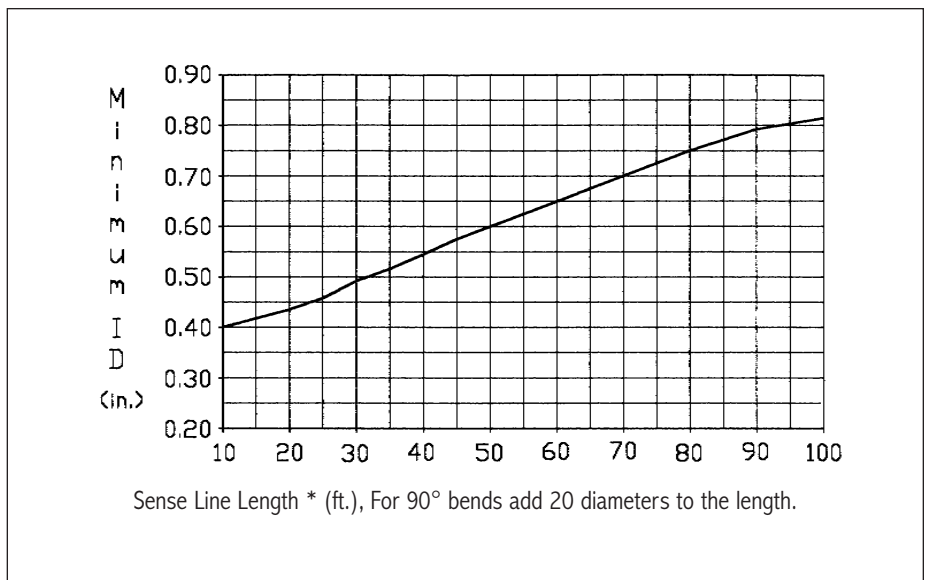

Fig. 2
Recommended Minimum Sense Line I.D. Based on Length

Start-Up

The blanketing valve is tested and set to the customer specified set point (as listed on the label) prior to shipment. Further adjustment in the field should not be required. After installation is complete, follow the steps below in order to put the blanketing valve into service:

1. Open the shut-off valve in the sense line between the blanketing valve and the tank.
2. Open the shut-off valve in the outlet line between the blanketing valve and the tank.
3. Check the blanketing gas supply line pressure to see that it corresponds to the pressure or pressure range listed on the label of the blanketing valve. If not, the supply pressure regulator should be adjusted accordingly. The maximum range in which the valve will operate is 10 to 200 PSIG.
4. Slowly open the shut-off valve in the blanketing gas supply line. Pressurizing the blanketing valve slowly pre-loads the valve so that it will not initially pop open.

If the tank pressure is above the blanketing valve set point, then the blanketing valve should seal immediately. Otherwise the valve will open and flow until the tank pressure rises above the set point. If the blanketing valve does not reseal at all, consult "Troubleshooting" on page 23.

Shut-Down

The blanketing valve must be depressurized when removing it from operation. Follow the steps below for system shut-down:

1. Close the shut-off valve in the blanketing gas supply line.
2. Close the shut-off valve in the sense line.
3. Pressure between the supply line shut-off and the seals inside the blanketing valve must be bled off. If the set point pressure is above atmospheric pressure, then the safest way to do this is to break the seal at the sense port of the blanketing valve. This will allow the pressure in the sense chamber to drop which will open the blanketing valve and bleed off the internal pressure into the tank. If the blanketing valve has a setting below atmospheric pressure, then a different method must be used. In addition to cracking the sense line, a connection between the supply line shut-off valve and the blanketing valve inlet port must be cracked to allow the high pressure gas to bleed out. The connection should be cracked slowly so that the high pressure gas bleeds, not bursts, out.
4. Close the shut-off valve in the outlet line.
5. Remove the supply line to the blanketing valve carefully in case there is still trapped pressure in the line.

MAINTENANCE

Purpose & Frequency

Periodic maintenance checks are recommended to ensure that the blanketing valve is in good operating condition. Debris in the valve or damaged seals are the most likely causes of operating problems. The frequency of routine maintenance necessary for the blanketing valve will depend on the severity of the operating conditions. The valve should be checked within a month of installation and then as determined appropriate after that. At minimum, the valve should be checked annually.

Leakage Check

Before performing any disassembly, it is a good idea to check for external leakage. This can be done by spraying or brushing soap around mating connections and bolts. If no leakage is detected around the #12 gasket or the #15 gasket (See Fig. 4), then it should not be necessary to disassemble the diaphragm case while performing routine maintenance.

Disassembly & Inspection

The following instructions are for maintenance of the standard components of the blanketing valve. Refer to the section entitled "Accessory Equipment" for instructions regarding optional accessories. Also, the diagrams in this section show a unit with standard ½" FNPT inlet and outlet connections. Except where noted, these instructions apply also to units with other inlet and outlet connections.

Protectoseal O-rings and gaskets are available from Protectoseal. See Table 6 on page 11 for soft goods kits which can be ordered.

CAUTION: The blanketing valve must be completely depressurized before any disassembly is performed. See the "shut-down" instructions above.

■ **DIAPHRAGM CASE** (See Fig. 4)

Remove the eight (8), #11 bolts, #13 nuts, and #4 lock washers. Carefully pull up the upper case assembly. Reach under the case to hold the #6 set spring in position while pulling the case up so that the spring and the #5 upper anchor do not fall over. The #9 diaphragm assembly and the #12 gasket can now be removed and checked. If there is any corrosion or damage to the gasket, it must be replaced.

Looking at the diaphragm assembly, the two (2), #21 plates should be clamped flat against the #22 diaphragm, and the diaphragm should be free of cracks, cuts or holes. See Fig. 5 for disassembly of the diaphragm assembly. Unthread the #24 stop (machined hex screw) from the #19 lower anchor. Note: This connection may be very tight due to thread adhesive being applied during assembly. The diaphragm and the #23 gasket should be free of cracks, cuts or holes. To remove the #14 lower case, remove the four (4), #7 hex screws. This exposes the #15 gasket which can then be inspected for corrosion or damage.

■ **MAIN VALVE** (See Fig. 6)

Position the blanketing valve so that the inlet points downward.

Refer to Fig. 6 before removing the #33 lower plug assembly. Identify the marks on the nut of the lower plug assembly and the bottom of the valve body. These marks, which should be lined up with each other, identify the proper position of the lower plug. This plug position is set at the factory for optimal performance of the blanketing valve. If the marks are not easy to see, then additional marks to identify the position during reassembly (with a felt tip pen for example) should be made on the nut and the pilot body before unscrewing the lower plug. Unscrew and remove the #33 lower plug assembly. When the plug is removed, the #30 poppet and attached parts will come out with it. Be careful not to damage the fine threads on the lower plug after removal. Set the body aside.

Grasping the lower plug assembly in one hand and the poppet in the other, firmly tug on the poppet to pull it out of the lower plug assembly. Be certain to do this in a slow, controlled manner so that the #31 poppet spring and the #32 spring pin do not fly out and get lost.

If the #14 lower diaphragm case has been removed, the #26 upper plug can be removed. The best way to do this is to slowly insert a phillips-head screwdriver into the bottom of the small hole in the upper plug and tap on it to push the plug out. Be very careful not to damage the inside bottom of the upper plug where the #28 O-ring seats. The O-rings can now be inspected for corrosion or wear.

Reassembly

When reassembling the blanketing valve, be sure to replace any worn or damaged O-rings and gaskets.

■ MAIN VALVE (See Fig. 6)

Before reassembling the main valve, the #28 and #29 O-rings should be lubricated with an appropriate lubricant. Reinsert all six O-rings in their proper positions. It is recommended that a conservative amount of anti-seize compound be applied to the fine threads of the lower plug before it is threaded back into the valve body. Hold the #30 poppet upside down, insert the #31 poppet spring in the recess in the end of the poppet, and insert the #32 spring pin into the spring. Slide the #33 lower plug assembly over the spring pin, spring and poppet and pop it into place. The poppet should move easily up and down inside the lower plug, being pushed up by the poppet spring. If it has been removed, push the #26 upper plug back into the #34 valve body. The orientation of the cross holes in the upper plug is not important. Slowly, being careful not to damage the end of the stem on the poppet or the seat at the bottom of the upper plug, insert the lower plug/poppet assembly into the valve body. Thread the lower plug into the body until the nut is seated against the valve body and the marks on nut and body line up.

■ DIAPHRAGM CASE (See Fig. 4)

With the blanketing valve body upright, place the #15 gasket on top of the body. Place the #14 lower case over the gasket and secure it with four (4), #7 hex screws and #8 lock washers, tightening to 96 in-lbs. If the #9 diaphragm assembly has been disassembled, then reassemble it as shown in Fig. 5. Apply thread adhesive to the thread connection and tighten until lock washer and plates are compressed.

Place the #9 diaphragm assembly on the lower case. Place the #12 gasket over the diaphragm and line up the bolt holes. Place the #6 set spring over the #19 lower anchor of the diaphragm assembly and insert the #5 upper anchor in the top of the spring. While holding the spring upright with one hand, slide the #10 upper case assembly until it rests on top of the diaphragm. Line up the bolt holes, insert the eight (8), hex screws, lock washers, and nuts and tighten to 96 in-lbs. Tighten the hex screws in the order as shown in Fig. 3.

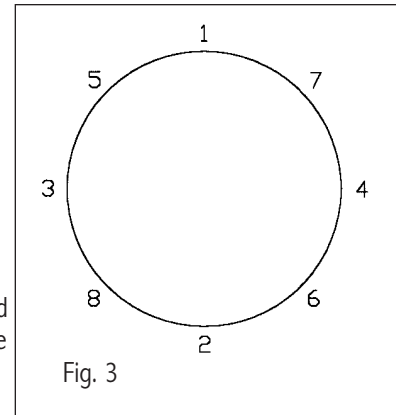

Reinstallation & System Check

Follow the installation and start-up instructions on page 2 to reinstall the blanketing valve after maintenance. After reinstalling the blanketing valve, a soap test should be performed again. If leakage is detected, then the point of leakage should be noted, and the valve should be disassembled as appropriate to identify the gasket or O-ring past which the leak is occurring.

If the blanketing valve flows continuously and does not seal after start-up, then the system should be shut down so that the problem can be identified. See the section "troubleshooting" on page 23 for possible problem sources. Any time that a blanketing valve is disassembled and reassembled, its operation should be monitored for a period afterward.

Set Point Adjustment w/o a Field Test Kit

Protectoseal Series 30 blanketing valves may be provided with a field test kit which facilitates checking and, if necessary, adjusting the set point. See "Field Test Accessories" on page 17 for more information. Instructions below provide a method of checking the set point for a blanketing valve which is not equipped with a field test kit. To add field test accessories to your unit contact the factory.

■ REQUIRED EQUIPMENT

1. High pressure / high flow air (or nitrogen) supply source with pressure gauge
2. Low pressure air supply source with manometer or pressure gauge
3. Collector tank (optional)
4. Clamping device to hold the blanketing valve
5. Wrenches
6. Screwdriver
7. Ear protection

■ TEST PROCEDURE (See Fig. 7)

1. Clamp the blanketing valve securely so that the outlet is open to blow into an area where it will not cause any harm. **WARNING:** A high surge of air will exit the outlet port of the blanketing valve when the valve opens. It is advisable to connect a piece of straight pipe to the outlet to direct the flow away from the person doing the test-ing.
2. Connect a line (1/2" NPT pipe size) from a high pressure / high flow air supply source to the blanketing valve inlet. The workable inlet supply pressure range of the Series 30 blanketing valve is 10 PSIG minimum / 200 PSIG maximum.
3. Connect a low pressure supply line to the 1/2" NPT sense port. The regulated pressure should be in the range of the set point of the valve. This line must be connected to a manometer or pressure gauge for pressure monitoring. Ideally, in order to obtain a more consistent static pressure reading, the line to the gauge or manometer should come from a collector tank. The pressure reading should be taken from the collector tank.
4. Unscrew and remove the #1 cap from the blanketing valve.
5. Check that the manometer or gauge is zeroed.
6. Set the low pressure supply as follows:

Set Point Range (inches W.C.)	Low Pressure Supply
-0.5 to 30.0	6" W.C. above set point
Above 30.0	2" Hg above set point

7. **CAUTION:** Put on ear protection. The flow out of the valve can be extremely loud.
8. Pressurize the low pressure supply line connected to the valve sense port as specified above.
9. Pressurize the high pressure supply line connected to the inlet port.
10. If the blanketing valve does not seal initially, the set point may be above the low pressure supply line pressure. Loosen the #3 jam nut and unscrew the #2 set screw to reduce the valve set point until the valve seals completely.
11. Set pressure adjustment: Cycle the pressure (up and down) to the sense port to determine the opening point of the blanketing valve. The pressure should be changed slowly (at approximately 0.1" W.C. per second for low settings). Adjust the #3 set screw so that the valve opens at the desired point. Please note the following:

- a) The set point of the Series 30 Blanketing Valve is specified as the pressure at which the valve opens.
 - b) The opening of the blanketing valve can be heard. The Series 30 valve is a spring loaded device. The amount of flow through the valve will increase as the sensed pressure is decreased below the valve's set point. The sound level associated with the flow through the valve will also increase as the sensed pressure is decreased below the valve's set point.
 - c) The valve will reseal at a sensed pressure above the pressure at which it opens.
12. After the desired set pressure has been attained, secure the position of the set screw by tightening the jam nut/lock washer until the lock washer is flat.
 13. If the opening pressure has been adjusted to a pressure different than that of the set point specified on the blanketing valve label, then the blanketing valve should be marked permanently to identify the new set point.
 14. Shut off the inlet line to the valve. Relieve the low pressure (sense line pressure). The valve should open when the sense line pressure is below the set point of the valve and relieve any high pressure remaining in the supply line.
 15. Disconnect all the test lines.
 16. Screw the #1 cap onto the spring guide and tighten it securely.
 17. Follow the blanketing valve installation and start-up instructions to install the blanketing valve into the system.

**Fig. 4
Blanketing Valve**

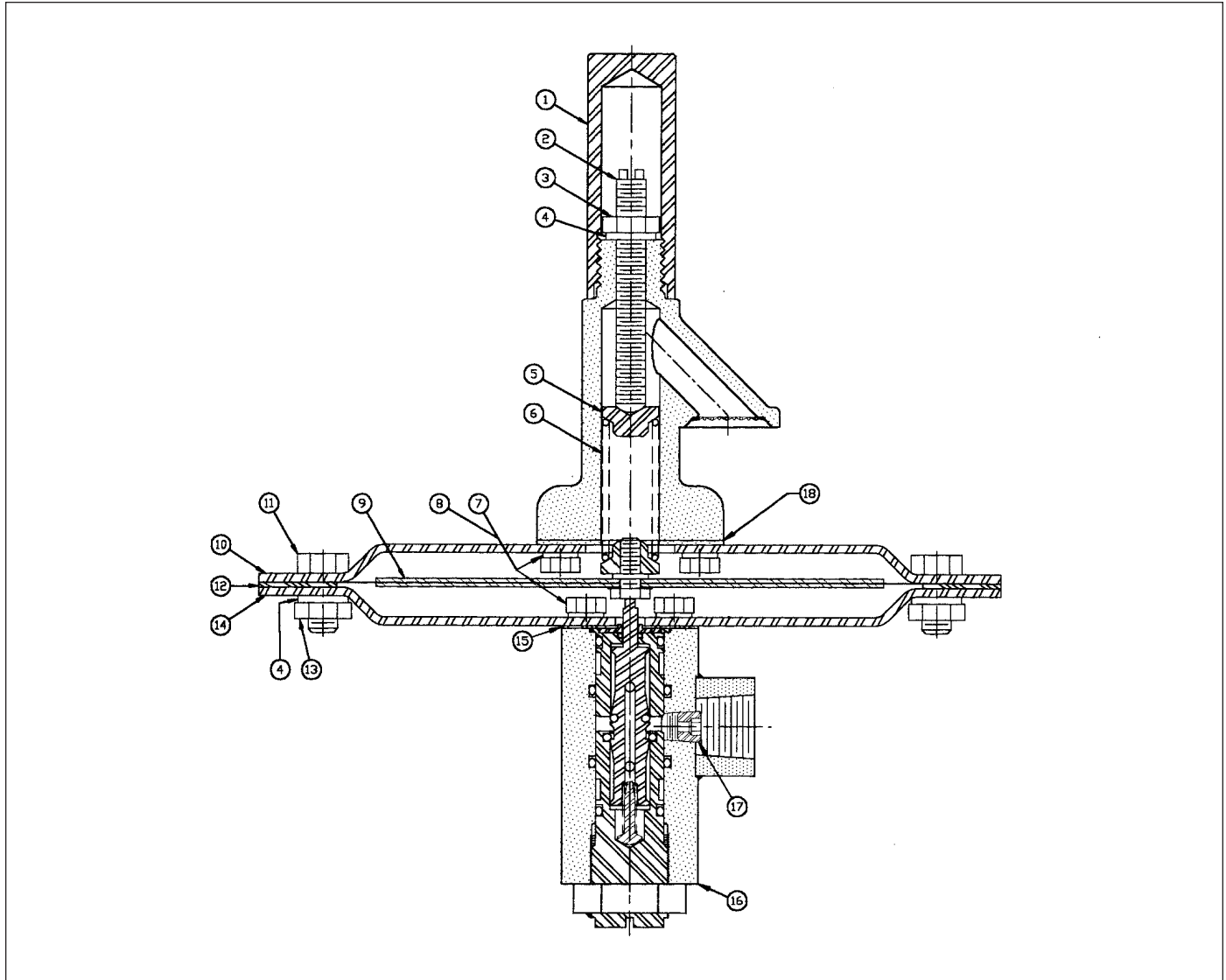

#	Qty.	Description	#	Qty.	Description	Part No.
1	1	Cap	11	8	Hex Screw, $\frac{3}{8}$ - 16 UNC x $\frac{3}{4}$	-
2	1	Set Screw	12	1	Gasket	20-18C-*
3	1	Jam Nut, $\frac{3}{8}$ - 24 UNF	13	8	Jam Nut, $\frac{3}{8}$ - 16 UNC	-
4	9	Lock Washer, $\frac{3}{8}$ "	14	1	Lower Case	-
5	1	Upper Anchor	15	1	Gasket	20-18D-*
6	1	Set Spring	16	1	Main Valve (Fig. 6)	-
7	8	Hex Screw, $\frac{1}{4}$ - 20 UNC x $\frac{1}{2}$	17	1	Flow Plug	-
8	8	Lock Washer, $\frac{1}{4}$ "	18	1	Gasket	20-18E-*
9	1	Diaphragm Assembly (Fig. 5)				
10	1	Upper Case Assembly				

* Suffix for the material code, see Table 5 on page 11.

Fig. 5
Diaphragm Assembly
(Item #9)

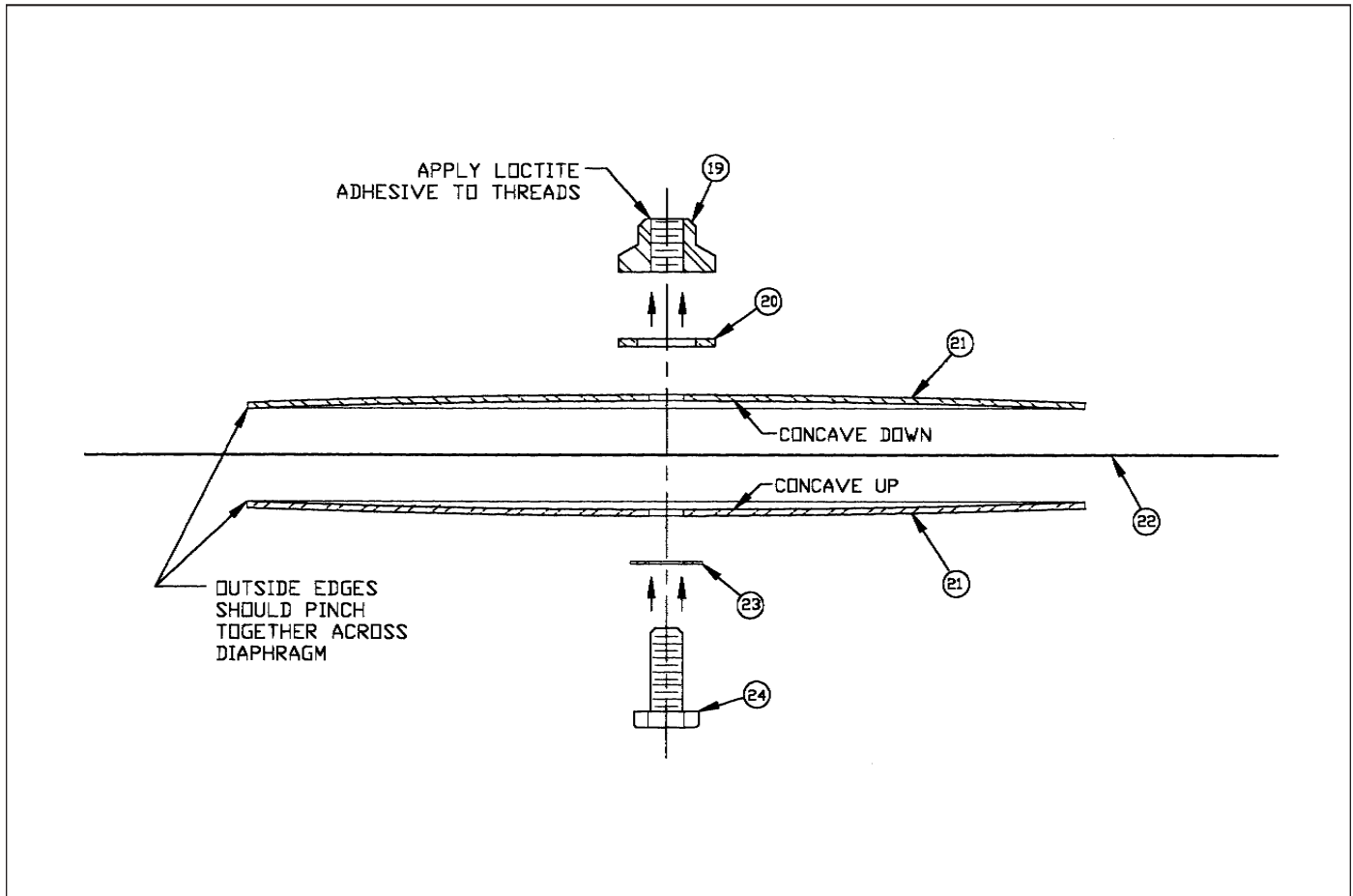

#	Qty.	Description	Part No.
19	1	Lower Anchor	-
20	1	Lock Washer 1/4"	-
21	2	Plate	-
22	1	Diaphragm	20-18A-107
23	1	Gasket	20-18B-107
24	1	Stop	-

**Fig. 6
Main Valve Assembly
(Item #16)**

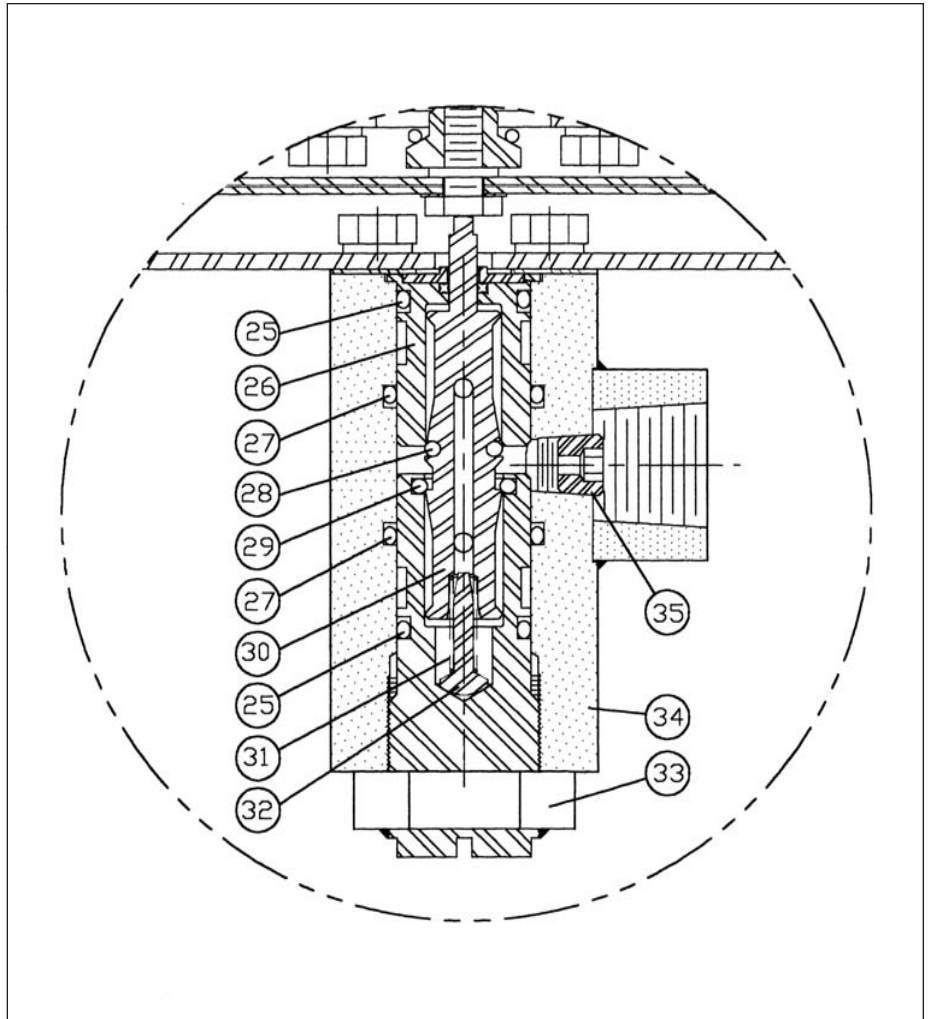

#	Qty.	Description	Part No.
25	2	O-Ring	20-R115-*
26	1	Upper Plug	✚
27	2	O-Ring	20-R118-*
28	1	O-Ring	20--R109-*
29	1	O-Ring	20-R112-*
30	1	Poppet	✚
31	1	Poppet Spring	-
32	1	Spring Pin	-
33	1	Lower Plug Assembly	✚
34	1	Valve Body	✚
35	1	Flow Plug	-
			-

* Suffix for the material code, see Table 5 on page 11.

✚ These parts must be replaced as a set.

Table 5
O-Ring & Gasket Codes & Suffixes

Model No. Code*	Material	Part No. Suffix (†)
A	Buna-N	-101
B	Neoprene	-100
C	Viton®	-118
D	EPDM	-136
E	Kalrez®**	-140
F	Chemraz®**	-138

* Digit #7 of part number.

** On units with Kalrez or Chemraz seals & gaskets, the diaphragm case gasket will be Buna-N.

Note: For all soft goods options, #36 Stem Seal (Fig. 6) will be FEP coated Buna-N.

Table 6
Soft Goods Kits

Kit Part No.	Contents
30-SGK1-†	All O-rings, Gaskets, & Diaphragms
30-SGK2-†	All O-rings

† Suffix for the material code, see Table 5.

Table 7
O-Ring Sizes

Part No.	Cross Section Dia.	I.D.
20-R109-†	.103	.299
20-R112-†	.103	.487
20-R115-†	.103	.674
20-R118-†	.103	.862

† Suffix for the material code, see Table 5.

**Fig. 7
Recommended Test
Set-Up**

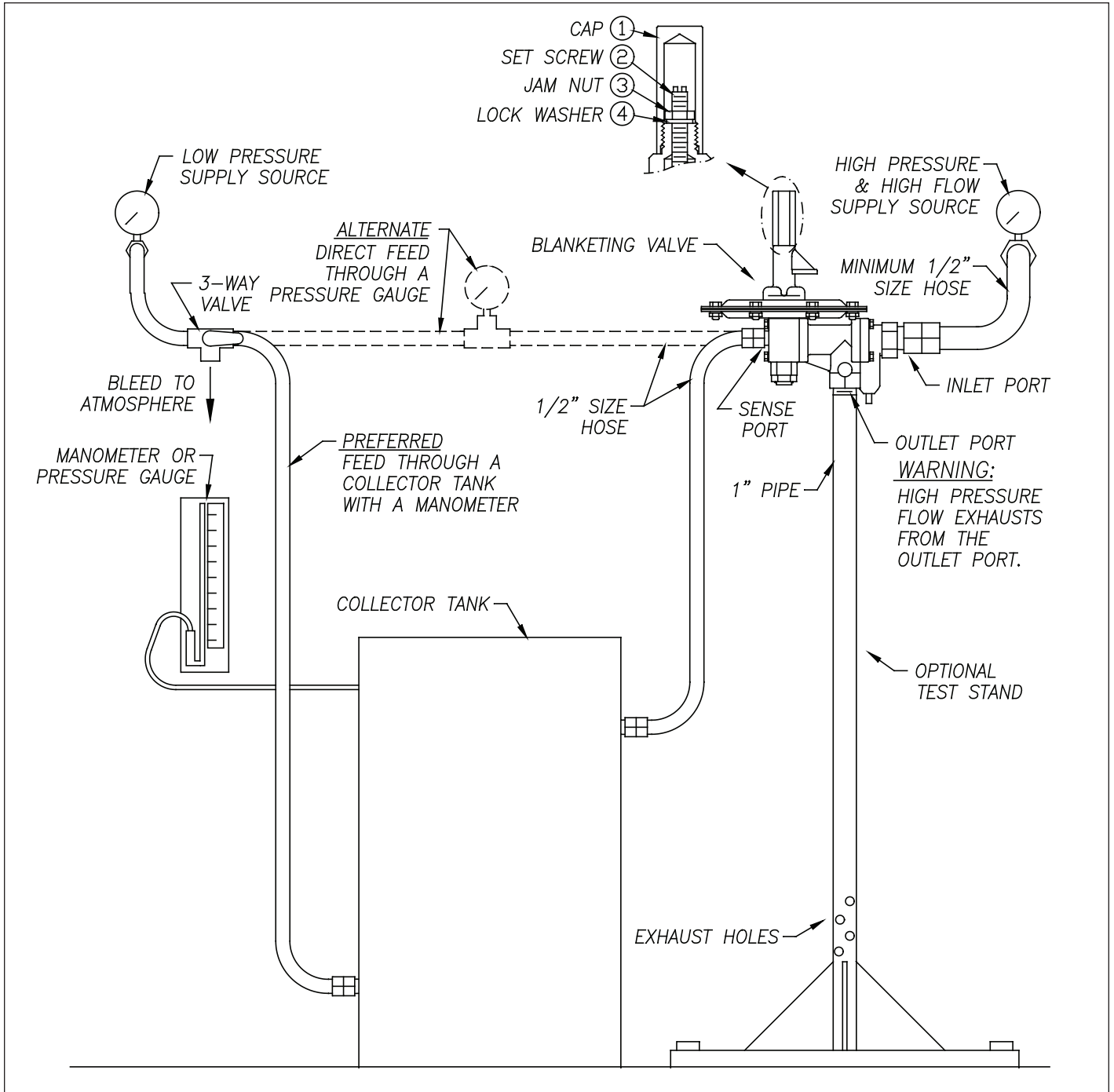

ACCESSORIES

Filter

■ FUNCTION

The optional supply line filter, with a 40 micron element, serves to keep any unwanted particles out of the blanketing valve flow stream. Particulate matter entering the valve can result in clogging of the flow passages and/or damage to the valve's seals. The blanketing valve should not be mounted in a supply line that does not include an effective filtering device.

■ MAINTENANCE

The following maintenance guidelines apply to a supply line filter that has been purchased as an option from The Protectoseal Company. If your system includes some other supply line filter, please contact the manufacturer of the filter for maintenance recommendations. Condensate may be drained from the bowl of the filter (See Fig. 8) by turning the drain cock (serrated knob on the bottom of the bowl). Note: It is possible to drain condensate from the bowl while the system is pressurized, but care must be taken in that the fluid will be expelled under a pressure equal to the supply line pressure of the system (typically 10 PSIG - 200 PSIG) for the blanketing valve application. CAUTION: DO NOT unscrew the bowl of the filter while the system is pressurized. After the supply line has been depressurized, the filter can be cleaned as follows:

1. Make sure that the supply line has been depressurized.
2. Unscrew the bowl of the filter. The bowl may be cleaned with a mild household detergent (do not use solvents or other such industrial cleaning agents).
3. Unscrew the filter element. Check the element for excessive blockage or visible holes. Damaged elements should be replaced immediately.
4. Reassemble the filter element and bowl. Make sure that the bowl is attached securely so that any seals are properly compressed. Make sure that the drain cock is completely closed.

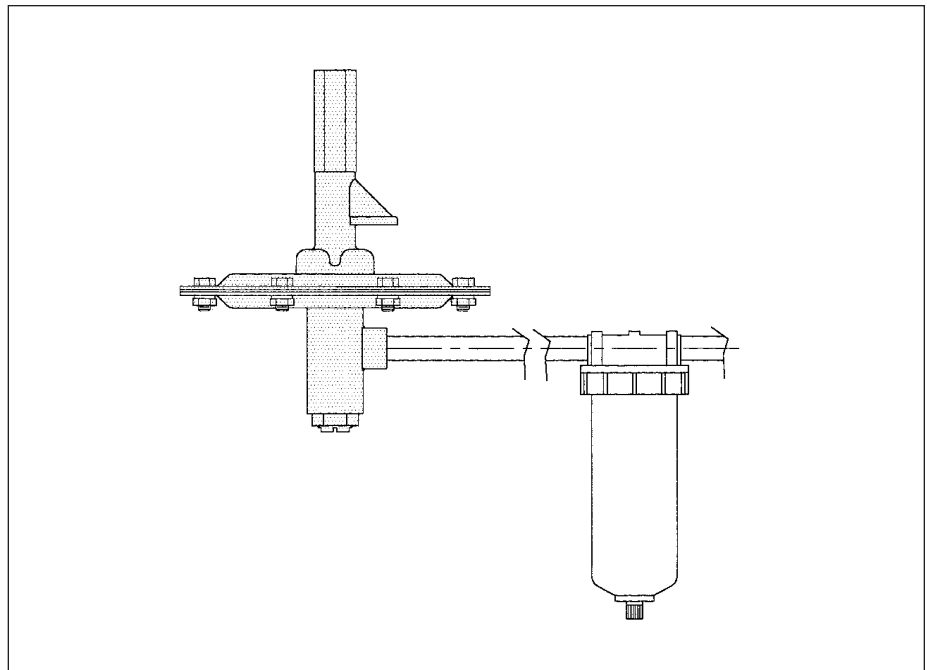

Fig. 8
Pilot Filter

Pressure Gauges

■ **FUNCTION**

Optional pressure gauges may be included which enable system pressure monitoring. The supply line pressure gauge will show the blanketing gas supply pressure at the inlet to and inside of the blanketing valve. The sense line pressure gauge will show the tank pressure being sensed by the blanketing valve through the sense line.

■ **MAINTENANCE**

When the blanketing valve has been completely depressurized, gauges may be removed for calibration checks. Replacement gauges can be ordered if necessary. The sense line gauge supplied by Protectoseal has a working pressure of up to 15 psig and so should not be damaged by fluctuations in tank pressure. Damage to the supply pressure gauge may indicate that the blanketing gas supply system was overpressurized at some point. Excessive supply pressure can cause blanketing valve failure and should be immediately investigated.

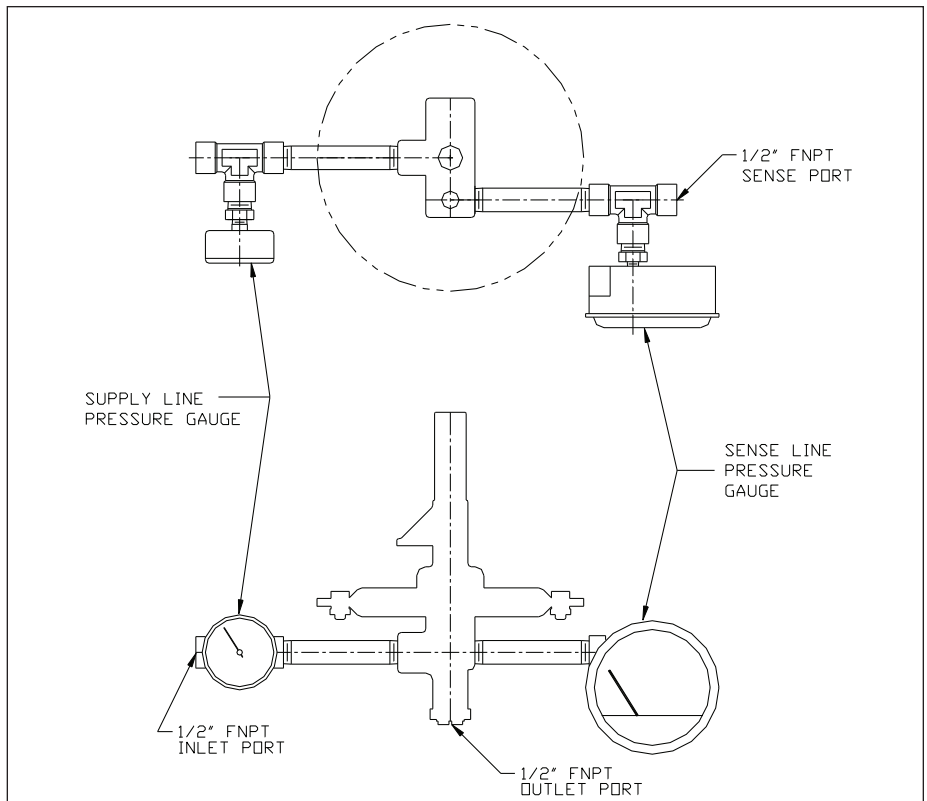

Fig. 9
Pressure Gauges

**Integral Purge
Accessories**

■ **FUNCTION**

The integral purge is used to create a small flow of blanketing gas at the blanketing valve outlet and/or the sense line connection in order to keep vapors from the material stored in the tank from corroding the blanketing valve. Due to the blanketing valve's stainless steel 316 construction, the availability of chemically resistant soft goods, and the high concentration of blanketing gas present in the blanketing valve, the integral purge should not be necessary except in very severe service conditions. Both the blanketing valve

outlet, and to a much lesser extent, the sense line will be purged with blanketing gas any time that the blanketing valve opens. The integral purge, however, flows continuously and also lessens the existence of standing vapors from the stored material when the blanketing valve is closed.

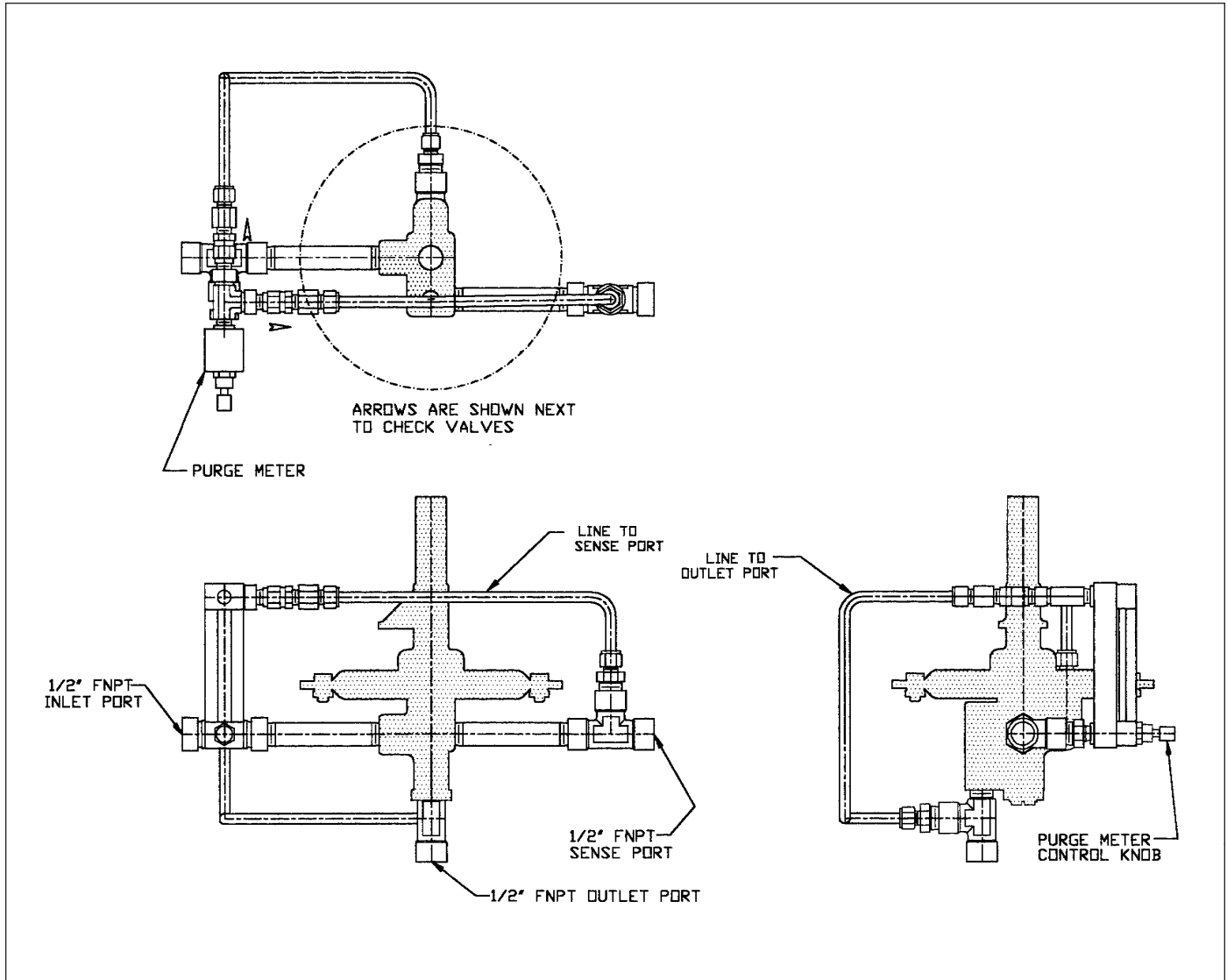

Fig. 10
Integral Purge System with Outlet & Sense Line Purges

■ OPERATION

The integral purge system uses the blanketing gas supply to create a trickle of flow at the outlet port and/or sense port. The purge meter (See Fig. 10) is used to control the flow going to either of these locations. A recommended flow through the meter is 0.5 SCFH. Flows higher than about 1.0 SCFH past the sense port are not recommended because they can create an artificially high pressure at the sense port leading to the valve opening at a tank pressure lower than the set point. If the purge is only to the outlet line, then

higher flows create only the problem of high supply gas usage.

The purge meter has a percent scale. The flow indicated will depend upon the blanketing gas supply pressure, the molecular weight of the blanketing gas, and (to a lesser degree) the operating temperature. See the below tables to determine the flows through the purge meter as follows:

Scale Reading for a Desired Flow:

$$\text{Scale Reading \%} = (\text{Desired Flow \{SCFH\}} \times 125 \times F1 \times F2 \times F3)$$

Flow Indicated at a Scale Reading:

$$\text{Flow \{SCFH\}} = (\text{Scale Reading \%}) / (125 \times F1 \times F2 \times F3)$$

Supply Pressure (PSIG)	F1
20	0.651
30	0.573
40	0.518
50	0.477
60	0.444
70	0.417
80	0.394
90	0.375
100	0.358
110	0.343
120	0.330
130	0.319
140	0.308
150	0.299
160	0.290
170	0.282
180	0.275
190	0.268
200	0.262

Table 8
Supply Pressure Factor (F1)

Gas	F2
Air	1.00
Carbon Dioxide	1.238
Helium	0.372
Natural Gas	0.775
Nitrogen	0.982

Table 9
Molecular Weight Factor (F2)

Temp. (°F)	Temp. (°C)	F3
0	-18	0.932
20	-7	0.952
40	4	0.971
60	16	0.991
70	21	1.000
80	27	1.009
100	38	1.028
120	49	1.046

Table 10
Temperature Factor (F3)

MAINTENANCE

The integral purge accessories should not normally require maintenance. When the blanketing valve has been removed for maintenance, the purge meter or purge system can be checked for blockage by hooking up a pressure line to the inlet of the purge meter (the bottom connection) and checking for flow at the outlet(s).

Since the blanketing gas should be clean, the purge meter should not usually require cleaning. However, if it is desired to do so, follow these steps:

1. Squeeze the clear plastic shield to unsnap it from the retainer.
2. Remove the glass tube by pushing it up (against the compression spring) and pulling it out.

3. Use tweezers to pull the float stop out from the top of the tube and then carefully tilt the tube to remove the float. Handle the float with care to avoid nicking or scratching it.
4. Clean the tube and float with mild detergent and water or with a suitable solvent. Use a soft cloth or tube brush to clean the meter tube. Do not expose the tube or float to extreme temperature changes.
5. The shield may be cleaned with detergent and water or with kerosine. If kerosine is used, follow up cleaning with detergent and water.
6. Reassemble in the reverse order of disassembly.

Units which have an outlet line purge will include one or more check valves which prevent back flow from the outlet when the blanketing valve opens. The blanketing valve will not function without these check valves. If it is desired to inspect these check valves, refer to the paragraph on check valve maintenance. Be certain to note the direction of the arrows on the check valves before removing them so that they will be reinstalled properly (the arrows should point away from the purge meter as shown in Fig. 10.).

Field Test Accessories

■ FUNCTION

The field test accessories make it possible to check the opening pressure of the valve in the field. Through a series of valves and a regulator, the blanketing gas supply is regulated down and directed into the sense chamber of the blanketing valve. A vacuum pump is also used in the low pressure / vacuum set point version in order to lower the pressure sufficiently. By lowering and raising this regulated pressure, the opening and closing point of the blanketing valve can be determined. Both the supply pressure gauge and the sense pressure gauge are included with the field test accessories.

Optional additional accessories are a 3-way valve for the outlet line and/or shut-off valve for the sense line. The 3-way valve makes it possible to divert outlet flow away from the tank if the blanketing valve is field tested while connected to the system. The auxiliary outlet port of the 3-way valve can either be connected to a collector or open directly to atmosphere. The sense line shut-off valve is used to isolate the sense chamber while conducting a field test. It provides easy accessibility if the valve is field tested while connected to the tank. It also provides a quick means of sealing off the sense port if the valve is removed from the tank for testing.

■ SET-UP

If the unit has been removed from the system:

1. Seal off the sense port by closing the sense line shut-off valve or inserting a pipe plug.
2. Position the outlet of the valve so that the high pressure flow can exhaust safely. The blanketing valve should be held securely by clamping or other means.
3. Connect a line from a pressure source to the valve inlet. The minimum restriction in this line should be a 1/2" pipe size diameter. The pressure source must be of sufficient capacity to open the blanketing valve fully, otherwise the valve will not operate consistently. Where possible, the inlet supply pressure should be equivalent to the blanketing gas supply pressure.

If the unit is still connected in the system:

1. Shut-off the blanketing gas supply to the inlet port.
2. Isolate the sense port from the tank by closing the sense line shut-off valve.

3. If the unit has a 3-way valve, turn the handle on the valve approximately 180° to close off the path to the tank and open up the blanketing valve outlet to the auxiliary port.
4. If the unit does not have a 3-way valve, you must leave the outlet line open and exhaust the blanketing valve into the tank. CAUTION: Exhausting into the tank while running a field test may cause the tank's pressure relief vents to open.

NOTES REGARDING THE SET POINT AND VALVE OPERATION:

1. The set point of the Protectoseal Series 30 Blanketing Valve is specified as the pressure at which the main valve opens.
2. The opening of the main valve will be audible. Flow through the valve will increase as the sensed pressure is reduced below the set point.
3. The main valve reseals above the pressure at which it opens.

■ TESTING - HIGHER PRESSURE SET POINT KIT

If the unit has set point range B, C, or D (as indicated by digit 6 of the model number) (above 3.0 to 69.2 inches W.C.) then this section applies. If the unit has a set point range of A, then proceed to the next section entitled "Testing - Low Pressure or Vacuum Set Point".

Follow these steps to determine the opening and resealing points (See Fig. 11):

1. Connect the test kit as shown at connection #1 and connection #2 (if it is not already attached). If the blanketing valve includes the integral purge option, the purge meter should be shut before using the field test unit.
2. Pull up the handle on the regulator to unlock it and turn the handle all the way counter-clockwise. This minimizes the outlet pressure of the regulator so that the regulator pressure gauge will not be damaged when inlet pressure is applied.
3. Turn the knobs on the needle valve and the bleed valve clockwise to close them.
4. Open shut-off valve #2 (at the hose end of the test kit).
5. CAUTION: Put on ear protection. The flow out of the valve can be extremely loud.
6. Pressurize the inlet to the blanketing valve.
7. Slowly open shut-off valve #1 (at the inlet of the test kit).
8. Turn the handle on the regulator clockwise to increase the outlet pressure until the regulator gauge reads approximately 13 PSIG.
9. Slowly open the needle valve to pressurize the sense line. Bring the pressure up above the set point (as indicated by the sense line pressure gauge).
10. Lower the sensed pressure by adjusting the knobs on the bleed valve, the needle valve and the regulator.
11. Note: If the blanketing valve has been removed from the system, then pressure in the sense chamber will bleed to atmosphere through the outlet port. Thus, there will not be a tight system and some gas must be continually bled in through the test kit in order to maintain the pressure at the sense port.
12. Cycle the sensed pressure up and down to determine the opening pressures. If the blanketing valve is not opening at the set point, see the section entitled "Set Point Adjustment" on page 6.
13. If other problems are experienced, refer to the troubleshooting guide. Double check your set-up and test procedures before attempting to adjust the set point or fix any other problems.

■ TESTING - LOW PRESSURE OR VACUUM SET POINT TEST KIT

If the unit has set point range A (-0.1 to 3.0 inches W.C.), then this section applies. Follow these steps to determine the blanketing valve's opening and resealing points (See Fig. 12).

1. Pull up the handle on the regulator to unlock it and turn the handle all the way counter-clockwise. This minimizes the outlet pressure of the regulator so that the regulator pressure gauge or the sense line gauge will not be damaged when inlet pressure is applied.
2. Turn the knob on the stem valve clockwise to close it.
3. Open shut-off valve #2 (at the hose end of the test kit).
4. CAUTION: Put on ear protection. The flow out of the valve can be extremely loud.
5. Pressurize the inlet to the blanketing valve.
6. Slowly open shut-off valve #1 (at the inlet of the test kit).
7. Turn the handle on the regulator clockwise to increase the outlet pressure until the regulator gauge reads 13 to 14 PSIG. (NOTE: Do not pressurize above 15 PSIG. Doing so could damage the sense line pressure gauge which is rated at 15 PSIG maximum.)
8. Lower the sensed pressure by turning the knob to open the stem valve. NOTE: Due to the small volume of the field test kit which controls the sense pressure, the blanketing valve may chatter near the set point. For very low and negative pressure set points the stem valve is opened to establish a flow pattern through the vacuum venturi tube and extract air (decrease pressure) in the valve's sense chamber.
9. Cycle the sensed pressure up and down to determine the opening pressures.
10. If the blanketing valve is not opening at the set point, refer to the section entitled "Set Point Adjustment" on page 6.

If other problems are experienced, refer to the troubleshooting section. Double check your set-up and test procedure before attempting to adjust the set point or fix any other problems.

■ ADJUSTING THE SET POINT (See Fig. 7)

1. Remove the #1 cap.
2. While securing the #2 set screw with a screwdriver, loosen the #3 jam nut.
3. Screw the set screw clockwise to make the unit open at a higher (or less negative) pressure or screw it counter-clockwise to make it open at a lower (or more negative) pressure.
4. Check the opening point using the field test kit as instructed above.
5. Iterate until the desired opening point is achieved.
6. Secure the position of the set screw with the jam nut and lock washer.
7. Thread on and tighten the cap.

■ AFTER TESTING

To depressurize the blanketing valve and test kit, shut off the inlet supply while the valve is flowing. Check that the pressure indicated on the sense line gauge is zero. Close shut-off valve #1 and shut-off valve #2. Disconnect the test kit at connection #1 and connection #2, if desired.

If the unit has been removed from the system:

1. Open the sense line shut-off valve or remove the pipe plug from the sense port.
2. Disconnect the line from the pressure source.
3. Follow the installation and start-up instructions to reinstall the blanketing valve.

If the unit is connected to the system:

1. Open the sense line shut-off valve.
2. Turn the handle on the 3-way valve back to its original position to open the path from the blanketing valve outlet to the tank and shut-off the auxiliary port.
3. Open the inlet supply shut-off valve.

Open and reset the purge meter if that option is included with the blanketing valve.

■ **MAINTENANCE**

If any of the components of the field test kit do not function properly, consult the factory for assistance in ordering replacement parts.

The following Figs. will appear on the next pages:

Fig. 11
Higher Pressure Set Point (above 3.0 to 69.2 inches W.C.) Field Test Kit
With Outlet Line 3-Way Valve & Sense Line Shut-Off Valve

Fig. 12
Low Pressure or Vacuum Set Point (-0.1 to 3.0 inches W.C.) Field Test Kit
Without Outlet Line 3-Way Valve or Sense Line Shut-Off Valve

Fig. 11
Higher Pressure Set Point
Field Test Kit

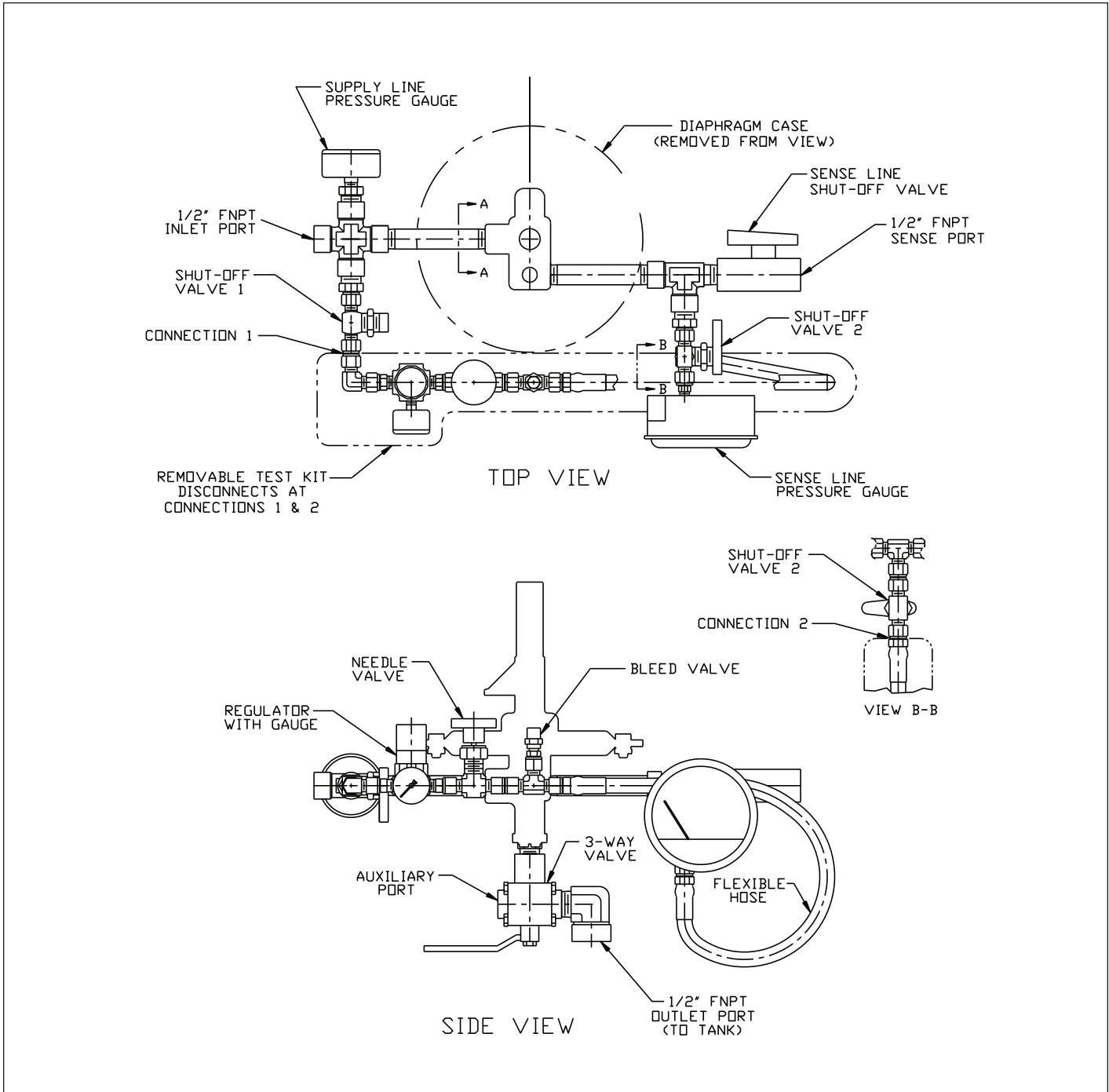

Fig. 11
Higher Pressure Set Point (above 3.0 to 69.2 inches W.C.) Field Test Kit
With Outlet Line 3-Way Valve & Sense Line Shut-off Valve

**Fig. 12
Low Pressure Field
Test Kit**

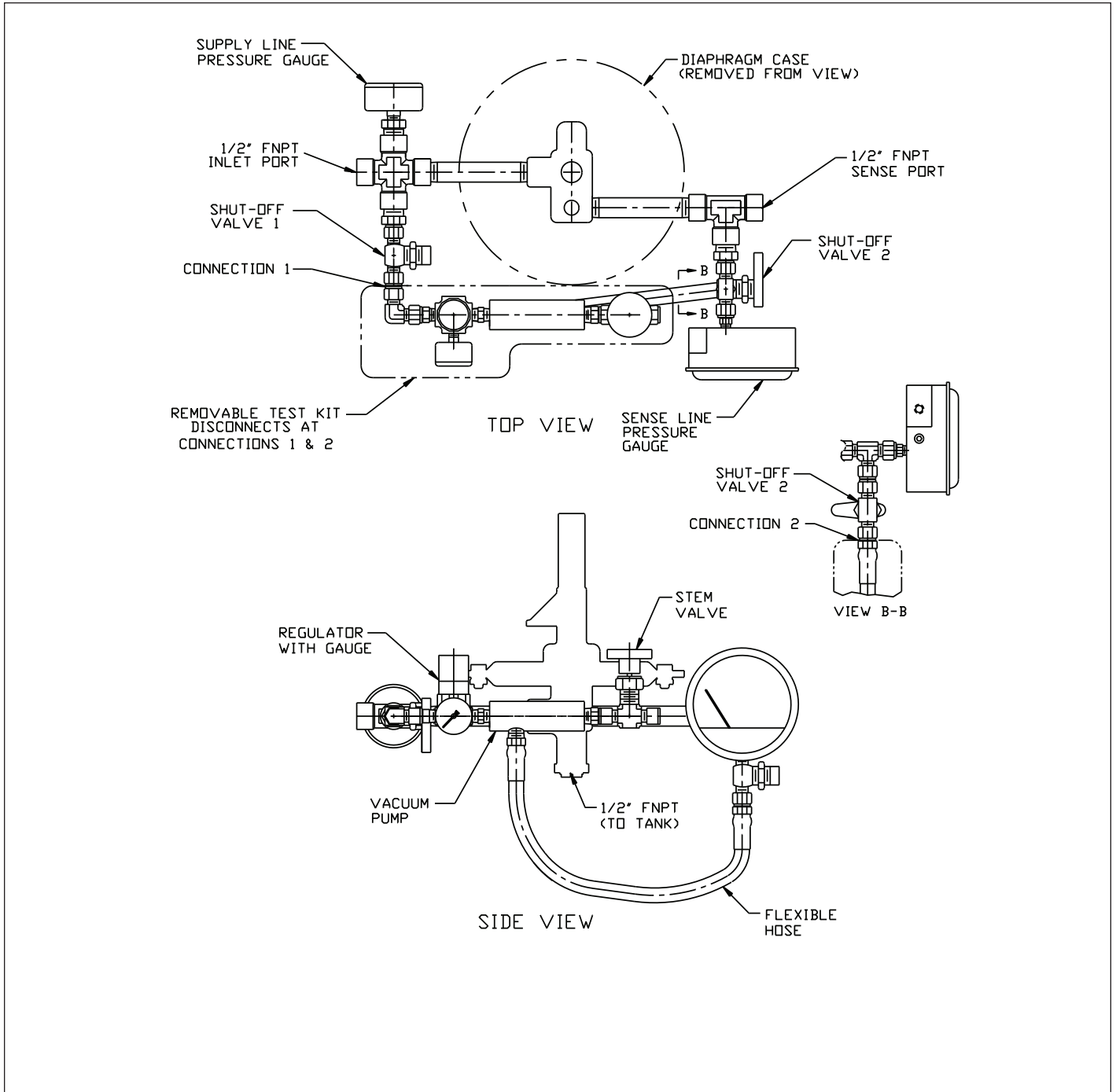

Fig. 12
Low Pressure or Vacuum Set Point (-0.1 to 3.0 inches W.C.) Field Test Kit
Without Outlet Line 3-Way Valve or Sense Line Shut-off Valve

Troubleshooting

Possible problems which could be encountered with a blanketing valve are listed below. Possible sources of the problems along with suggestions for investigating the problems are also included. Refer to the maintenance instructions for directions on disassembly and reassembly of the blanketing valve and accessories. Refer to Figure 2 through 6 as necessary. NOTE: ** Refers to optional equipment which may not be included with your unit

WARNING: Always depressurize the blanketing valve before disassembling.

■ PROBLEM 1 : The blanketing valve does not open at all.

- 1.1. The blanketing gas supply is empty or shut down or the shut-off valve in the supply line is closed.
 - ✓ Inspect the blanketing gas supply source and supply line.
- 1.2. The shut-off valve in the outlet line is closed.
 - ✓ Open the shut-off valve.
- 1.3. The sense line shut-off valve is closed or the sense line is blocked.
 - ✓ Open the sense line shut-off valve. Inspect the sense line and clear blockage.
- 1.4. The set point is too low.
 - ✓ Has the #2 set screw (Fig. 7) been adjusted? If this set screw has been backed out, the set point of the valve will have been lowered, possibly below atmospheric pressure.
 - ✓ The set point may be checked. See either the sections regarding "Set Point Adjustment" on page 6, "Field Test Accessories"*** on page 17, or consult the factory for assistance.
- 1.5. The diaphragm assembly or the poppet is stuck. Remove the #10 upper case assembly for inspection.
 - ✓ Is the #9 (Fig. 5) diaphragm assembly intact? Make sure assembly is complete and replace #22 diaphragm if damaged.
 - ✓ Was the #6 set spring jammed or out of position when the upper case assembly was removed?
 - ✓ Does the #30 (fig. 6) poppet move down and return when you press down on the stem protruding into the lower case from the valve body? If not, disassemble the valve and inspect O-rings, spring and the spring pin before reassembly.

■ PROBLEM 2: The blanketing valve flows full open without resealing.

- 2.1. The set point of the valve is too high. If the set point of the blanketing valve is above that of the pressure relief devices, then neither the blanketing valve nor the pressure relief devices will close.
 - ✓ Compare the specified set points for the blanketing valve and the pressure relief devices. The blanketing valve set point should be lower than that of the vents. For example, for a blanketing valve set point of 10" W.C. the vent should be set at least 12" W.C.
 - ✓ The set point may be checked. See the section regarding "Set Point Adjustment" on page 6, or "Field Test Accessories"*** on page 17.
- 2.2. The valve poppet is stuck open.
 - ✓ See section 1.5 above. Note: particulate matter in the blanketing gas stream can plug or jam the valve open or damage seals. The blanketing gas stream must be filtered and free of solids.
- 2.3. There is a leak in the sense line connection or in the tank.
 - ✓ Isolate the blanketing valve from the tank. Pressurize the tank and verify that it holds pressure.
 - ✓ Check the sense line and all connections to verify that they do not leak.

-
- 2.4 There is a leak from the sense diaphragm chamber.
 - ✓ Leak test the diaphragm case around the perimeter and around the bolts.
 - ✓ Leak test around the #15 gasket between the lower case and the valve body.
 - ✓ Check the sense diaphragm for a hole or any damage.
 - ✓ Check the #23 gasket in the diaphragm assembly (Fig. 5).
 - 2.5 The diaphragm assembly or the poppet is stuck.
 - ✓ See section 1.5.
 - 2.6 An O-ring or seal has blown out or been damaged.
 - ✓ Disassemble and inspect seals. Replace any damaged components.
 - 2.7 The blanketing valve was not reassembled properly after maintenance.
 - ✓ Verify that all O-rings and seals are in place.
 - ✓ Verify that the #31 spring, #32 spring pin and #30 poppet are in place.
 - ✓ Verify that the shut off valve isolating accessory items such as the “Field Test Accessories”** are closed.
-

■ **PROBLEM 3:** The blanketing valve leaks continuously.

- 3.1. Debris is holding the valve poppet open.
 - ✓ Disassemble the unit, check for debris, clean and reassemble.
 - 3.2. An O-ring has been blown out or damaged.
 - ✓ Disassemble and inspect.
 - 3.3. There is a leak in the sense chamber or sense line.
 - ✓ See 2.3 and 2.4.
 - 3.4. The diaphragm assembly is stuck or is prevented from moving completely to the sealing position.
 - ✓ See 1.5.
-

■ **PROBLEM 4:** The blanketing valve opens above or below the set point.

- 4.1. The set point is incorrect.
 - ✓ The set point may be checked. See the section regarding “Set Point Adjustment” on page 6, or “Field Test Accessories”** on page 17.
 - 4.2. The sense line is restricted.
 - ✓ Verify that the sense line is correctly sized and is not blocked (Fig. 2).
 - 4.3 There is a leak from the sense line, the tank or the sense diaphragm chamber.
 - ✓ See 2.3 and 2.4.
-

■ **PROBLEM 5:** The pressure vent or other pressure relief device opens before the blanketing valve closes.

- 5.1. The set point of the two devices are too close together.
 - ✓ See 2.1.
- 5.2. The venting device is opening below its specified set point.
 - ✓ Contact the manufacturer to verify set point of the vent.
- 5.3 The blanketing valve is opening above its specified set point.
 - ✓ Has the #2 set screw been adjusted? If it has been screwed in, then the blanketing valve opening pressure will have been increased.
 - ✓ The set point may be checked. See the section regarding “Set Point Adjustment” on page 6, or “Field Test Accessories”** on page 17.
- 5.4 The blanketing valve is closing too far above its set point.
 - ✓ Check that the #33 lower plug assembly (Fig. 6) is screwed all the way in so the nut stop is flush with the valve body and the marks on the nut line up with the marks on the body.
 - ✓ Check for any debris in the valve body or damage to the seals.
- 5.5 The blanketing valve flow capacity is too high for the system.
 - ✓ Refer to the Series 30 Blanketing Valve “User Guide” for assistance in determining flow capacity sizing.

- PROBLEM 6: The vacuum vent or other vacuum relief device opens.
- 6.1. The blanketing valve set point is below (more negative than) the vacuum vent set point.
 - ✓ Verify that the set point of the blanketing valve is higher than the set point of the vacuum relief device. The set point of one or the other may have to be changed. Refer to the Series 30 “User Guide” for assistance in determining proper set points.
 - 6.2. The blanketing valve is opening below its set point.
 - ✓ See 1.4.
 - 6.3. The blanketing valve flow capacity is not high enough for the system.
 - ✓ Refer to the Series 30 Blanketing Valve “User Guide” for assistance in determining flow capacity sizing.
-

- PROBLEM 7: The blanketing valve cycles, repeatedly opening and closing.
- 7.1. The blanketing valve flow capacity is too high for the system.
 - ✓ Refer to the User’s Guide for assistance in determining flow capacity sizing.
 - 7.2. The sense line is not providing a true static pressure reading of the tank’s vapor space.
 - ✓ Verify that the sense line connection is located and sized properly (Fig. 2).

NOTE: ** Refers to optional equipment which may not be included with your unit.



225 Foster Ave., Bensenville, IL 60106-1690
P 630.595.0800 F 630.595.8059
info@protectoseal.com www.protectoseal.com