

CAUTION:

If any questions arise concerning the proper installation or maintenance of our products, please contact Protectoseal or one of our Authorized Representatives.

When installing any Protectoseal device, the legal, corporate and advisory safety regulations and procedures appropriate for the specific installation site must be fully understood and followed.



NOTE 1: Protectoseal Gauge Hatches are available in free venting and lock down models. The lock down versions are equipped with a threaded wing nut that is used to clamp the hatch cover in the sealed position.

NOTE 2: Some Protectoseal Gauge Hatches utilize metal to metal seating rather than FEP or elastomeric diaphragms. In these cases, a reliable seal depends on the smoothness of the seat and cover contact surfaces.

INSTALLATION PROCEDURE:

1. Remove and discard protective cardboard and tape from the gauge hatch.

2. Remove protective flange covers.
3. Check carefully to insure that all packing materials are removed from on or inside the vent.
4. Mount the hatch to the appropriate tank flange using gaskets compatible with service conditions. For best performance, the vent should be mounted level so that the seating surfaces are no more than 1° off horizontal.

Note: The gauge should be positioned so that the cover is free to open fully without interfering with surrounding equipment or structures.

5. Verify that the gauge hatch cover moves freely from closed to full open position. Secure the cover of a lock down gauge hatch with the wing nut assembly.

Series 4970

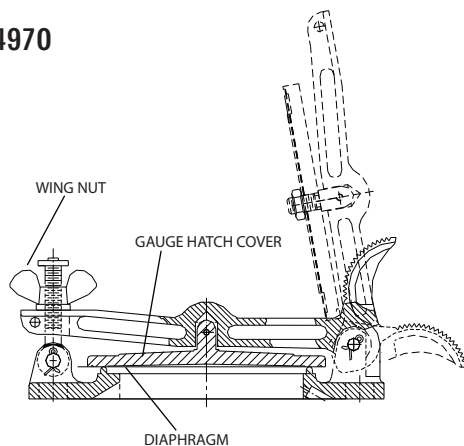

Series 5960

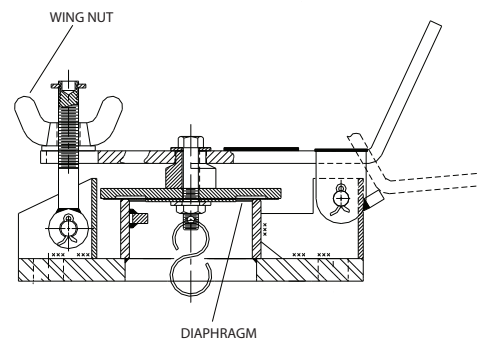

Series 4980

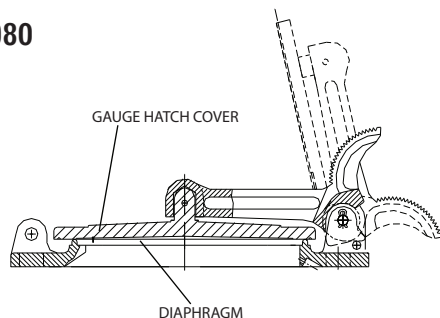

Series 4960

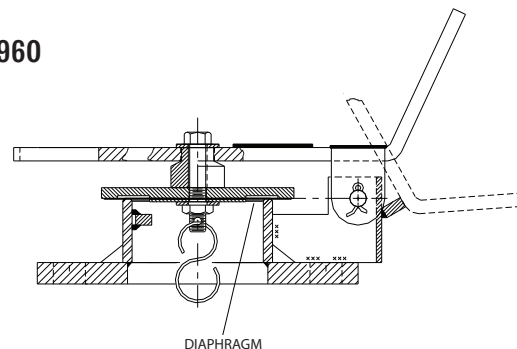

MAINTENANCE:

Protectoseal recommends that our products be inspected and maintained according to the normal maintenance schedule of the facility. At a minimum, maintenance should be conducted annually. More frequent maintenance may be required, and should be scheduled, for unusual service conditions.

CAUTION: When maintaining any Protectoseal device, the legal, corporate and advisory safety regulations and procedures appropriate for the specific installation site must be fully understood and followed.

CAUTION: Tank vapor space pressure or vacuum should be relieved before any maintenance operations are undertaken.

MAINTENANCE PROCEDURE:

1. Lift the gauge hatch cover to its full open position. If a lock down version is installed, the wing nut hold down must be loosened before the cover is opened.
2. Remove any loose dirt or foreign material from the

housing or seat area of the gauge hatch.

3. Inspect and clean the machined seating surface of the gauge hatch. Seat should be free of nicks, mars or accumulations of foreign material.

CAUTION: Do not use a file or other sharp tool to clean the seating surface.

4. Inspect the gauge hatch cover. If the cover is damaged the gauge hatch should be replaced.
5. Inspect the diaphragm. The diaphragm must be clean, flat and smooth. If the diaphragm is deteriorated, it must be replaced. All fasteners must be tightened securely.
6. Make sure that the gauge hatch cover is free to move through its entire range of motion.
7. Secure the lock down wing nut, if applicable (lock down gauge hatches).

ADDITIONAL PRODUCTS FROM PROTECTOSEAL

Series 18540



Pipe-Away Pressure Vacuum Relief Vent for applications that require hazardous vapors be processed into manifolded piping and not released into the atmosphere

Series 7800



Emergency Vent protects tanks against rupture or explosion resulting from excessive internal pressure caused by exposure to fires.

Series 4950



Vent Line / In-Line Parallel Plate Flame Arrester is designed for installation in open vent pipe or bleed lines from storage or processing tanks. Suitable for NEC Group D (IEC Group IIA) vapors

Series 830



Combination Pressure / Vacuum Relief Vent & Flame Arrester provides pressure and vacuum relief as well as protection from propagation of externally introduced flames. Suitable for NEC Group D (IEC Group IIA) vapors.