

**CAUTION:**

If any questions arise concerning the proper installation or maintenance of our products, please contact Protectoseal or one of our Authorized Representatives.

When installing any Protectoseal device, the legal, corporate and advisory safety regulations and procedures appropriate for the specific installation site must be fully understood and followed.

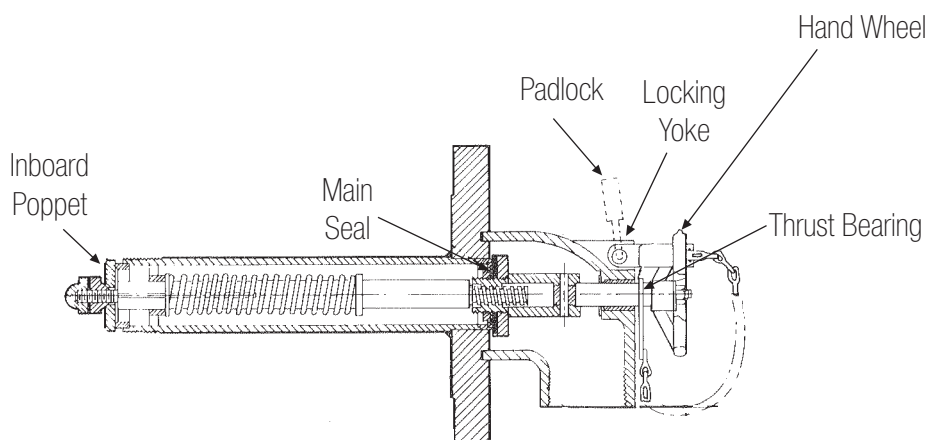

**INSTALLATION PROCEDURE:**

1. Remove all protective packing from unit. (Exposed poppet at end of valve is taped shut for shipment.)
2. Turn valve hand wheel counter clockwise to a point where main valve seat is open but poppet at end of valve is still closed. Push hand wheel inward to check that poppet opens. Poppet should return to closed position when pressure is released. Open valve fully to check that both poppet and main valve seat are open. Close valve.
3. Mount valve on tank using proper flange bolts. Tighten diagonally.
4. If bell reducer and dip pipe are to be used, install at inboard of valve. To assure adequate flow, provide bell reducer as follows:
 

<u>Valve No.</u>	<u>Bell Reducer</u>	<u>Dip Pipe Size</u>
663F	1½" x 2½" NPT	2½" NPT
664F	2½" x 3" NPT	3" NPT
666F	3½" x 4" NPT	4" NPT
5. With valve closed, insert locking yoke around spoke of hand wheel until holes match hole in body boss. Insert suitable pin or lock.

## MAINTENANCE:

Protectoseal recommends that our products be inspected and maintained according to the normal maintenance schedule of the facility. At a minimum, maintenance should be conducted annually. More frequent maintenance may be required, and should be scheduled, for unusual service conditions.

**CAUTION: When maintaining any Protectoseal device, the legal, corporate and advisory safety regulations and procedures appropriate for the specific installation site must be fully understood and followed.**

**CAUTION: Tank vapor space pressure or vacuum should be relieved before any maintenance operations are undertaken.**

## MAINTENANCE PROCEDURE:

1. On occasion, a piece of dirt, rust or other foreign material become lodged on the main valve seat. This can usually be dislodged by the following procedures:
  - a) Open the valve to the point where the main valve is fully open but the inboard poppet remains closed.
  - b) Intermittent hand pressure applied to the hand wheel will provide spurts of liquid flow which, in most cases, will flush out the foreign matter.
2. If the main valve seat disc is worn or damaged, it can be replaced by removing the outer valve trim as follows:
  - a) Open valve slightly to make sure inner poppet is seated tightly. Loosen and remove the two bonnet bolts. Remove the bonnet assembly by pulling horizontally while rotating hand wheel counter clockwise until valve stem threads are disengaged.

3. The valve seat in the body should be inspected for nicks or other damage. A new seat disc can now be installed if needed.
4. Check the FEP Film thrust bearing against which the main valve stem back-seats (visible thru valve outlet). If worn or damaged, remove the hand wheel nut and hand wheel. The stem can now be pulled through the bonnet and the thrust bearing replaced. Reassemble stem, bonnet, hand wheel and nut.
5. Before replacing the bonnet assembly, check the bonnet gasket and nut.
6. Reinstall the bonnet assembly. To avoid opening the in-board poppet, the hand wheel must be turned clockwise during reassembly to advance on the stem threads as the bonnet is guided to its proper position. Tighten the bonnet bolts alternately and evenly to provide a secure seat at the gasket joint.

## ADDITIONAL PRODUCTS FROM PROTECTOSEAL

Series 18540



Pipe-Away Pressure Vacuum Relief Vent for applications that require hazardous vapors be processed into manifolded piping and not released into the atmosphere

Series 7800



Emergency Vent protects tanks against rupture or explosion resulting from excessive internal pressure caused by exposure to fires.

Series 4950



Vent Line / In-Line Parallel Plate Flame Arrester is designed for installation in open vent pipe or bleed lines from storage or processing tanks. Suitable for NEC Group D (IEC Group IIA) vapors

Series 830



Combination Pressure / Vacuum Relief Vent & Flame Arrester provides pressure and vacuum relief as well as protection from propagation of externally introduced flames. Suitable for NEC Group D (IEC Group IIA) vapors.