

THERMOPLASTIC RESIN VENTS

Highly Resistant to Acids & Chemically Hostile Environments

**PROTECTOSEAL**

SERIES*	STYLE	SIZES
6240	End-of-Line Vacuum	2" - 8"
7800B	End-of-Line Pressure	2" - 8"
8540	End-of-Line Pressure & Vacuum	2" - 8"
16240	Side Mounted Vacuum	2" - 8"
17800	Pipe-Away Pressure or Vacuum	2" - 8"
18540	Pipe-Away Pressure & Vacuum	2" - 8"

*** PREFIX DESIGNATIONS**

"PVC" - Polyvinyl Chloride "CPVC" - Chlorinated Polyvinyl Chloride

"PP" - Polypropylene "PE" - Polyethylene

"PVDF" - Polyvinylidene Fluoride

SUFFIX DESIGNATION - Refer to Cat. No. in dimension chart

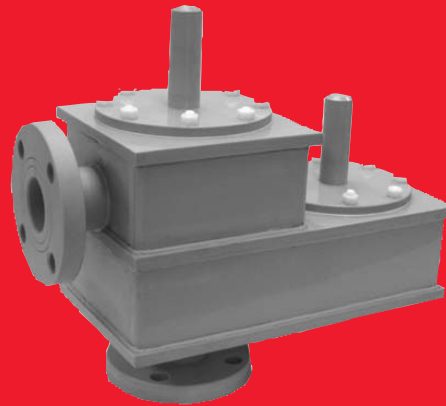

POLY VENTS

OBJECTIVE

Protectoseal's Thermoplastic Resin Vents are designed to provide pressure and/or vacuum relief to control hazardous vapors that would attack metallic vents or components. Through the use of these plastic materials, a wide range of tank storage, product conservation, and environmental regulation applications can be served. These include chemical processing, petrochemical, petroleum, pharmaceutical, pulp & paper, semiconductor, ultrapure water, wastewater and food / beverage. These vents may be effective in severe applications such as hydrochloric, hydrofluoric and sulfuric acids at high process temperatures. The versatility of these materials allows for their use instead of exotic metals.

TECHNIQUE

Normal conservation breather vents feature pressure and vacuum pallets in the vent housing that retard intake of air and escape of vapors under normal conditions. Pallets open and close to permit only the intake or outlet relief necessary to remain within permissible working limits and avoid damage to tanks, low pressure vessels and piping. In pipe-away models, relieved vapors are piped away through a flanged connection.

SPECIAL FEATURES

Fast Inspection, Easy Maintenance. Highest quality rugged design and light weight provides for a long service life, ease of installation, inspection and preventative maintenance.

Maintains Accurate Pressure Settings. Factory tested and certified prior to shipment. Every unit meets Protectoseal's stringent requirements for accuracy. Leakage on vent pallets at standard settings is 1 SCFH or less at 90% of the set pressure.

Automatic Condensate Drainage. Self-draining body design keeps condensate away from seating surface.

Air-Cushioned Seating. Protectoseal's patented and exclusive air-cushioned seating for low evaporation losses. FEP film diaphragms are standard, other materials can be furnished on special request. The pallets have peripheral guiding and center stabilizing stem to ensure proper alignment and tight seating.

Numerous Sizes Available. All vents in the sizes shown above mate with standard flanged 125# ANSI or DIN PN 16 bolting specifications. Other drilling patterns are also available upon special request.

PRO-FLOW® Sizing and Selection Software.

Use PRO-FLOW® to select the correct size unit for pressure and vacuum relief calculated in accordance with API 2000, ISO 28300, NFPA 30 and OSHA 1910.106.

CONSTRUCTION

Protectoseal vents manufactured from Polyvinyl Chloride (PVC), Chlorinated Polyvinyl Chloride (CPVC), Polypropylene (PP), Polyethylene (PE) and Polyvinylidene Fluoride (PVDF) are highly resistant to acids and chemically hostile environments, yet extremely rugged and durable in construction. The vents are constructed using no metal parts including exterior hardware. This will ensure a long service life in corrosive atmospheres.

"PVC" Prefix - Polyvinyl Chloride (PVC) body, cover and hood; PVC pallet assembly components; FEP diaphragms; PVC hardware; PVC, 316 S.S. or lead weights, if required.

"CPVC" Prefix - Chlorinated Polyvinyl Chloride (CPVC) body, cover and hood; CPVC pallet assembly components; FEP diaphragms; CPVC hardware; 316 S.S. or lead weights, if required.

"PP" Prefix - Polypropylene (PP) body, cover and hood; Polypropylene pallet assembly components; FEP diaphragms; Polypropylene hardware; 316 S.S. or lead weights, if required.

"PE" Prefix - Polyethylene (PE) body, cover and hood; Polyethylene pallet assembly components; FEP diaphragms; Polyethylene hardware; 316 S.S. or lead weights, if required.

"PVDF" Prefix - Polyvinylidene Fluoride (PVDF) body, cover and hood; PVDF pallet assembly components; FEP diaphragms; PVDF hardware; 316 S.S. or lead weights, if required.

Available Options.

- Alternate diaphragm materials
- Derakane® 470, Derakane® 411 encapsulated weights

Series No. 6240 - End-of-Line Vacuum Relief Vent (Dimensions shown are for reference only, contact factory for certified drawings.)

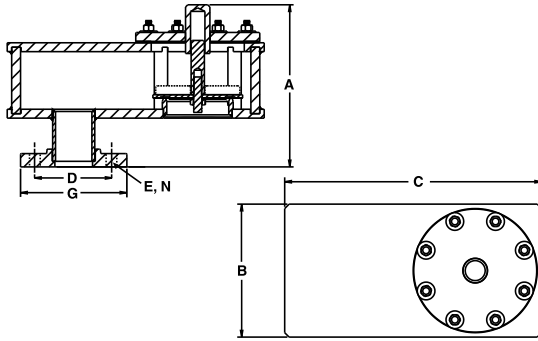

Cat. No.*	Flange Size	Ht. A	Width B	Length C	B.C. D	Dia. G	Dia. E	Holes N
6242B	2"	9 ¹ / ₈ "	7 ¹ / ₂ "	14 ¹ / ₂ "	4 ³ / ₄ "	6"	3/4"	4
6243B	3"	9 ³ / ₈ "	7 ¹ / ₂ "	14 ¹ / ₂ "	6"	7 ¹ / ₂ "	3/4"	4
6244B	4"	9 ⁵ / ₈ "	9 ¹ / ₄ "	18 ³ / ₄ "	7 ¹ / ₂ "	9"	3/4"	8
6246C	6"	14"	11 ¹ / ₂ "	23"	9 ¹ / ₂ "	11"	7/8"	8
6248C	8"	14 ¹ / ₂ "	14 ¹ / ₂ "	27 ¹ / ₂ "	11 ³ / ₄ "	13 ¹ / ₂ "	7/8"	8

* Prefix Designations: "PVC" - Polyvinyl Chloride; "CPVC" - Chlorinated Polyvinyl Chloride; "PP" - Polypropylene; "PE" - Polyethylene; "PVDF" - Polyvinylidene Fluoride

Series No. 7800B - End-of-Line Pressure Relief Vent (Dimensions shown are for reference only, contact factory for certified drawings.)

Cat. No.*	Flange Size	Ht. A	Width B	Length C	B.C. D	Dia. G	Dia. E	Holes N
7802B	2"	8 ¹ / ₄ "	10 ¹ / ₂ "	10 ¹ / ₂ "	4 ³ / ₄ "	6"	3/4"	4
7803B	3"	8"	10 ¹ / ₂ "	10 ¹ / ₂ "	6"	7 ¹ / ₂ "	3/4"	4
7804B	4"	9"	12 ⁷ / ₈ "	12 ⁷ / ₈ "	7 ¹ / ₂ "	9"	3/4"	8
7806B	6"	10 ⁷ / ₈ "	15 ¹ / ₈ "	15 ¹ / ₈ "	9 ¹ / ₂ "	11"	7/8"	8
7808B	8"	12"	18 ¹ / ₂ "	18 ¹ / ₂ "	11 ³ / ₄ "	13 ¹ / ₂ "	7/8"	8

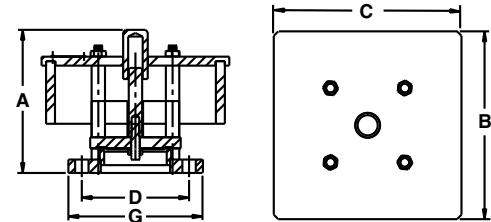

* Prefix Designations: "PVC" - Polyvinyl Chloride; "CPVC" - Chlorinated Polyvinyl Chloride; "PP" - Polypropylene; "PE" - Polyethylene; "PVDF" - Polyvinylidene Fluoride

Series No. 8540 - End-of-Line Pressure & Vacuum Breather Vent (Dimensions shown are for reference only, contact factory for certified drawings.)

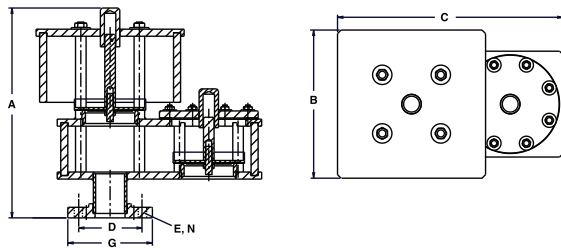

Cat. No.*	Flange Size	Ht. A	Width B	Length C	B.C. D	Dia. G	Dia. E	Holes N
8542B	2"	14 ⁷ / ₈ "	10 ¹ / ₂ "	16"	4 ³ / ₄ "	6"	3/4"	4
8543B	3"	15"	10 ¹ / ₂ "	16"	6"	7 ¹ / ₂ "	3/4"	4
8544B	4"	16"	12 ⁷ / ₈ "	20 ¹ / ₂ "	7 ¹ / ₂ "	9"	3/4"	8
8546C	6"	19 ⁵ / ₈ "	15 ¹ / ₈ "	24 ⁷ / ₈ "	9 ¹ / ₂ "	11"	7/8"	8
8548C	8"	21 ¹ / ₄ "	18 ¹ / ₂ "	30 ¹ / ₄ "	11 ³ / ₄ "	13 ¹ / ₂ "	7/8"	8

* Prefix Designations: "PVC" - Polyvinyl Chloride; "CPVC" - Chlorinated Polyvinyl Chloride; "PP" - Polypropylene; "PE" - Polyethylene; "PVDF" - Polyvinylidene Fluoride

Series No. 16240 - Side Mounted Vacuum Relief Vent (Dimensions shown are for reference only, contact factory for certified drawings.)

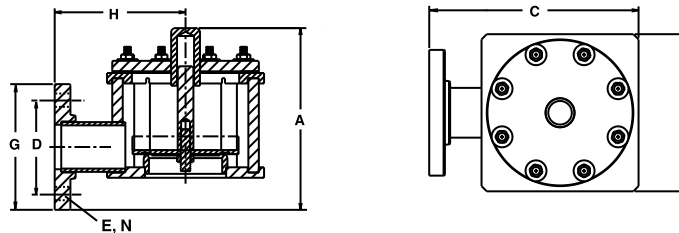

Cat. No.*	Flange Size	Valve Size	Ht. A	Width B	Length C	Width H	B.C. D	Dia. G	Dia. E	Holes N
16240B2	2"	2"	8 ³ / ₄ "	7 ¹ / ₂ "	10"	6 ¹ / ₄ "	4 ³ / ₄ "	6"	3/4"	4
16240B3	3"	3"	8 ¹ / ₈ "	7 ¹ / ₂ "	10 ¹ / ₄ "	6 ¹ / ₂ "	6"	7 ¹ / ₂ "	3/4"	4
16240B4	4"	4"	12"	9 ¹ / ₄ "	12 ¹ / ₄ "	7 ¹ / ₂ "	7 ¹ / ₂ "	9"	3/4"	8
16240C6	6"	6"	15 ⁷ / ₈ "	11 ¹ / ₂ "	14 ¹ / ₄ "	8 ¹ / ₂ "	9 ¹ / ₂ "	11"	7/8"	8
16246C8	8"	6"	16 ¹ / ₈ "	11 ¹ / ₂ "	14 ¹ / ₄ "	8 ¹ / ₂ "	11 ³ / ₄ "	13 ¹ / ₂ "	7/8"	8

* Prefix Designations: "PVC" - Polyvinyl Chloride; "CPVC" - Chlorinated Polyvinyl Chloride; "PP" - Polypropylene; "PE" - Polyethylene; "PVDF" - Polyvinylidene Fluoride

Series No. 17800 - Pipe-Away Pressure or Vacuum Breather Vent (Dimensions shown are for reference only, contact factory for certified drawings.)

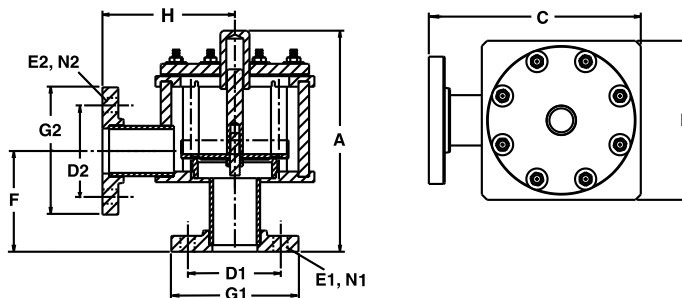

Cat. No.*	Flange Size Inlet x Outlet	Ht. A	Width B	Length C	F	H	B.C. D1	B.C. D2	Dia. G1	Dia. G2	Dia. E1	Dia. E2	Holes N1	Holes N2
17802B2	2" x 2"	10 ¹ / ₂ "	7 ¹ / ₂ "	10"	4 ³ / ₄ "	6 ¹ / ₄ "	4 ³ / ₄ "	4 ³ / ₄ "	6"	6"	3/4"	3/4"	4	4
17802B3	2" x 3"	11 ¹ / ₂ "	7 ¹ / ₂ "	10"	5 ¹ / ₄ "	6 ¹ / ₂ "	4 ³ / ₄ "	6"	6"	7 ¹ / ₂ "	3/4"	3/4"	4	4
17803B3	3" x 3"	11 ⁵ / ₈ "	7 ¹ / ₂ "	10 ¹ / ₄ "	5 ¹ / ₂ "	6 ¹ / ₂ "	6"	6"	7 ¹ / ₂ "	7 ¹ / ₂ "	3/4"	3/4"	4	4
17803B4	3" x 4"	11 ⁵ / ₈ "	9"	10 ¹ / ₄ "	6"	6 ¹ / ₂ "	6"	7 ¹ / ₂ "	7 ¹ / ₂ "	9"	3/4"	3/4"	4	8
17804B4	4" x 4"	13 ¹ / ₂ "	9 ¹ / ₄ "	11 ⁷ / ₈ "	6"	7 ¹ / ₄ "	7 ¹ / ₂ "	7 ¹ / ₂ "	9"	9"	3/4"	3/4"	8	8
17804B6	4" x 6"	13 ¹ / ₂ "	11"	12"	7"	7 ³ / ₈ "	7 ¹ / ₂ "	9 ¹ / ₂ "	9"	11"	3/4"	7/8"	8	8
17806C6	6" x 6"	17 ³ / ₈ "	11 ¹ / ₂ "	14 ³ / ₈ "	7"	8 ⁵ / ₈ "	9 ¹ / ₂ "	9 ¹ / ₂ "	11"	11"	7/8"	7/8"	8	8
17806C8	6" x 8"	17 ³ / ₈ "	11 ¹ / ₂ "	14 ³ / ₈ "	8"	8 ⁵ / ₈ "	9 ¹ / ₂ "	11 ³ / ₄ "	11"	13 ¹ / ₂ "	7/8"	7/8"	8	8
17808C10	8" x 10"	20 ³ / ₄ "	13"	16 ¹ / ₄ "	10 ¹ / ₂	9 ³ / ₄ "	11 ³ / ₄ "	14 ¹ / ₄ "	13 ¹ / ₂ "	16"	7/8"	1"	8	12

* Prefix Designations: "PVC" - Polyvinyl Chloride; "CPVC" - Chlorinated Polyvinyl Chloride; "PP" - Polypropylene; "PE" - Polyethylene; "PVDF" - Polyvinylidene Fluoride

Series No. 18540 - Pipe-Away Pressure & Vacuum Breather Vent (Dimensions shown are for reference only, contact factory for certified drawings.)

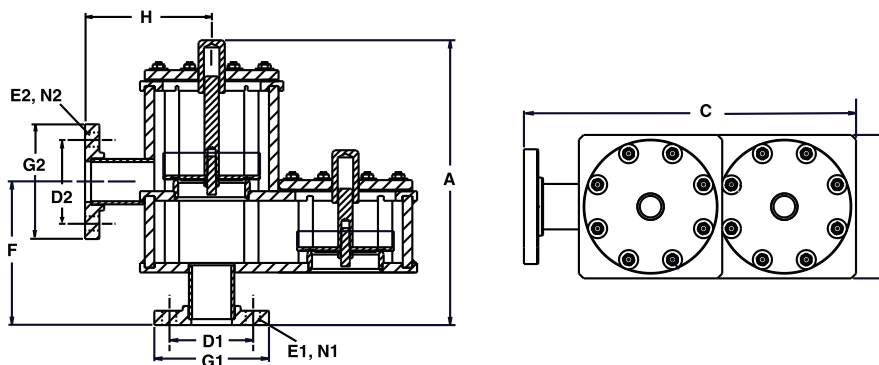

Cat. No.*	Flange Size Inlet x Outlet	Ht. A	Width B	Length C	F	H	B.C. D1	B.C. D2	Dia. G1	Dia. G2	Dia. E1	Dia. E2	Holes N1	Holes N2
18542B2	2" x 2"	14 ⁷ / ₈ "	7 ¹ / ₂ "	17 ¹ / ₂ "	7 ¹ / ₂ "	6 ⁵ / ₈ "	4 ³ / ₄ "	4 ³ / ₄ "	6"	6"	3/4"	3/4"	4	4
18542B3	2" x 3"	14 ⁷ / ₈ "	7 ¹ / ₂ "	17 ¹ / ₂ "	8"	6 ⁷ / ₈ "	4 ³ / ₄ "	6"	6"	7 ¹ / ₂ "	3/4"	3/4"	4	4
18543B3	3" x 3"	15 ¹ / ₈ "	7 ¹ / ₂ "	17 ¹ / ₂ "	8 ¹ / ₄ "	6 ⁷ / ₈ "	6"	6"	7 ¹ / ₂ "	7 ¹ / ₂ "	3/4"	3/4"	4	4
18543B4	3" x 4"	15 ¹ / ₈ "	9"	17 ¹ / ₂ "	8 ³ / ₄ "	6 ⁷ / ₈ "	6"	7 ¹ / ₂ "	7 ¹ / ₂ "	9"	3/4"	3/4"	4	8
18544B4	4" x 4"	17 ¹ / ₈ "	9 ¹ / ₄ "	21 ³ / ₄ "	9 ¹ / ₈ "	7 ⁵ / ₈ "	7 ¹ / ₂ "	7 ¹ / ₂ "	9"	9"	3/4"	3/4"	8	8
18544B6	4" x 6"	16 ⁷ / ₈ "	11"	21 ³ / ₄ "	10 ¹ / ₄ "	7 ³ / ₈ "	7 ¹ / ₂ "	7 ¹ / ₂ "	9"	9"	3/4"	3/4"	8	8
18546C6	6" x 6"	23 ¹ / ₈ "	11 ¹ / ₂ "	26"	12 ¹ / ₂ "	8 ¹ / ₂ "	9 ¹ / ₂ "	9 ¹ / ₂ "	11"	11"	7/8"	7/8"	8	8
18546C8	6" x 8"	23 ¹ / ₈ "	11 ¹ / ₂ "	26"	13 ¹ / ₂ "	8 ¹ / ₂ "	9 ¹ / ₂ "	11 ³ / ₄ "	11"	13 ¹ / ₂ "	7/8"	7/8"	8	8
18548C10	8" x 10"	25 ³ / ₈ "	14 ¹ / ₄ "	30 ³ / ₄ "	15 ¹ / ₈ "	9 ³ / ₄ "	11 ³ / ₄ "	14 ¹ / ₄ "	13 ¹ / ₂ "	16"	7/8"	1"	8	12

* Prefix Designations: "PVC" - Polyvinyl Chloride; "CPVC" - Chlorinated Polyvinyl Chloride; "PP" - Polypropylene; "PE" - Polyethylene; "PVDF" - Polyvinylidene Fluoride

STANDARD PRESSURE AND/OR VACUUM SETTINGS (Consult factory for settings outside of STANDARD range.)

Cat. No.*	Flange Size	MINIMUM SETTINGS				MAXIMUM SETTINGS	
		PVC / CPVC / PP / PE		PVDF Only		All Materials	
		Pressure oz./in. ²	Vacuum oz./in. ²	Pressure oz./in. ²	Vacuum oz./in. ²	Pressure oz./in. ²	Vacuum oz./in. ²

* Prefix Designations: "PVC" - Polyvinyl Chloride; "CPVC" - Chlorinated Polyvinyl Chloride; "PP"- Polypropylene; "PE" - Polyethylene; "PVDF" - Polyvinylidene Fluoride

END-OF-LINE VACUUM RELIEF VENT

6242B	2"	N/A	0.50	N/A	0.75	N/A	4.00
6243B	3"	N/A	0.50	N/A	0.75	N/A	4.00
6244B	4"	N/A	0.50	N/A	0.50	N/A	4.00
6246C	6"	N/A	0.50	N/A	0.50	N/A	4.00
6248C	8"	N/A	0.50	N/A	0.75	N/A	4.00

END-OF-LINE PRESSURE RELIEF VENT

7802B	2"	1.00	N/A	1.00	N/A	16.00	N/A
7803B	3"	1.00	N/A	1.00	N/A	16.00	N/A
7804B	4"	1.00	N/A	1.00	N/A	16.00	N/A
7806B	6"	1.00	N/A	1.00	N/A	16.00	N/A
7808B	8"	1.00	N/A	1.00	N/A	16.00	N/A

END-OF-LINE PRESSURE & VACUUM BREATHER VENT

8542B	2"	0.50	0.50	0.75	0.75	16.00	4.00
8543B	3"	0.50	0.50	0.75	0.75	16.00	4.00
8544B	4"	0.50	0.50	0.50	0.50	16.00	4.00
8546C	6"	0.50	0.50	0.50	0.50	16.00	4.00
8548C	8"	0.50	0.50	0.75	0.75	16.00	4.00

SIDE MOUNTED VACUUM RELIEF VENT

16240B2	2"	N/A	0.50	N/A	0.75	N/A	16.00
16240B3	3"	N/A	0.50	N/A	0.75	N/A	16.00
16240B4	4"	N/A	0.50	N/A	0.50	N/A	16.00
16240C6	6"	N/A	0.50	N/A	0.50	N/A	16.00
16246C8	8"	N/A	0.50	N/A	0.50	N/A	16.00

PIPE-AWAY PRESSURE OR VACUUM RELIEF VENT

17802B2	2" x 2"	0.50	0.50	0.75	0.75	16.00	16.00
17802B3	2" x 3"	0.50	0.50	0.75	0.75	16.00	16.00
17803B3	3" x 3"	0.50	0.50	0.75	0.75	16.00	16.00
17803B4	3" x 4"	0.50	0.50	0.75	0.75	16.00	16.00
17804B4	4" x 4"	0.50	0.50	0.50	0.50	16.00	16.00
17804B6	4" x 6"	0.50	0.50	0.50	0.50	16.00	16.00
17806C6	6" x 6"	0.50	0.50	0.50	0.50	16.00	16.00
17806C8	6" x 8"	0.50	0.50	0.50	0.50	16.00	16.00
17808C10	8" x 10"	0.50	0.50	0.75	0.75	16.00	16.00

PIPE-AWAY PRESSURE / VACUUM BREATHER VENT

18542B2	2" x 2"	0.50	0.50	0.75	0.75	16.00	4.00
18542B3	2" x 3"	0.50	0.50	0.75	0.75	16.00	4.00
18543B3	3" x 3"	0.50	0.50	0.75	0.75	16.00	4.00
18543B4	3" x 4"	0.50	0.50	0.75	0.75	16.00	4.00
18544B4	4" x 4"	0.50	0.50	0.50	0.50	16.00	4.00
18544B6	4" x 6"	0.50	0.50	0.50	0.50	16.00	4.00
18546C6	6" x 6"	0.50	0.50	0.50	0.50	16.00	4.00
18546C8	6" x 8"	0.50	0.50	0.50	0.50	16.00	4.00
18548C10	8" x 10"	0.50	0.50	0.75	0.75	16.00	4.00



225 Foster Ave., Bensenville, IL 60106-1690
 P 630.595.0800 F 630.595.8059
 info@protectoseal.com www.protectoseal.com