

Elmac Technologies Limited - Operating Instructions

Requirements to EN ISO 16852, ATEX Directive 2014/34/EU



Please register your product with Elmac Technologies to receive exclusive discounts on future spares orders. Scan QR code or visit <https://elmactechnologies.com/services/>

INSTALLATION AND MAINTENANCE INSTRUCTIONS

INTRODUCTION

Flame arresters and their replaceable elements are fitted with nameplates (refer to figure 1), stating the following information: -

- Full name, address, telephone and fax numbers of manufacturer.
- Burn rating group (BC) and short time burn duration when applicable.
- The specific marking of explosion protection.
- Notified body number.
- Nominal bore size of arrester/element.
- Maximum operating pressure.
- Maximum run-up distance (Lu/D).
- Model number of flame arrester/element.
- Maximum operating temperature.
- Explosion group for which the arrester/element may safely be used.
- Year of construction.
- Elmac serial number of flame arrester/element (quote when requesting spare parts).
- The ATEX certificate number.

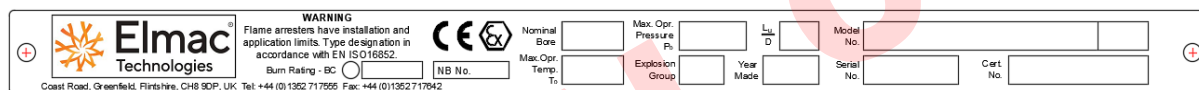

Figure 1 – Nameplate General Layout

Spare crimped ribbon elements are marked with the below information on their periphery: -

- Manufacturer's Name.
- Explosion group for which the arrester/element may safely be used.
- Elmac serial number of flame arrester/element (quote when requesting spare parts).
- Year of construction.

WARNINGS

Flame arresters have installation and application limits.

Flame arresters must be installed in accordance with this IOM. If there is any doubt, please contact Elmac Technologies Limited. Liability for any losses or damages resulting from incorrect or improper use of flame arresters shall be the responsibility of the end users.

Rev.	Description	Issued By	Date
6	Scan QR code added and Elmac logo updated.	D. Greenough	29.06.2021
5	Fifth Issue (format updated, and additional cautions added relating to installation).	O. Tuncer	28.09.2017
4	Fourth Issue (changes to ATEX Directive from 94/9/EC to 2014/34/EU).	O. Tuncer	03.09.2016
3	Third Issue (instruction added regarding threaded instruments and ports).	O. Tuncer	03.09.2015
2	Second Issue (element removal instructions incorporated).	O. Tuncer	13.01.2015
1	First Issue.	O. Tuncer	25.07.2014

Description: Installation & Maintenance Instructions for In-Line Deflagration Flame Arresters (ATEX)		 Elmac Technologies Limited, Coast Road, Greenfield, Flintshire, CH8 9DP United Kingdom	
Drawn By: Ozkan Tuncer	Date: 02.07.2014		
Checked By: D. Greenough	Date: 29.06.2021	Document No. ELN-00085 Page 1 of 11	Revision 6
Tel: +44 (0) 1352 717 555	The information contained herein is confidential and is the property of Elmac Technologies Ltd. The information is issued on the understanding that no part thereof be disclosed to a third party without written consent of Elmac Technologies Ltd.		
Fax: +44 (0) 1352 717 642			
E-Mail : sales@elmactech.com			
Web: http://www.elmactechnologies.com			

Elmac Technologies Limited - Operating Instructions

Requirements to EN ISO 16852, ATEX Directive 2014/34/EU



Please register your product with Elmac Technologies to receive exclusive discounts on future spares orders. Scan QR code or visit <https://elmactechnologies.com/services/>

Caution!

1. Please inspect the equipment when it is received and report any damage (if any).
2. Connection flanges are generally protected where possible. The customer must check and remove any 'Transport Protection' and 'Flange Protectors' prior to installation.
3. Inspect the equipment for physical damage or internal contamination before installation and use of the equipment.

DESCRIPTION

A flame arrester uses an element with small apertures which allow gas or vapour to pass. The apertures are sufficiently small, so the combustion process cannot continue, and flame is subsequently contained or extinguished.

For a short time burn proof of deflagration flame arrester, the flame arrester is equipped with at least one temperature sensor to allow continuous monitoring of the surface temperature of the flame arrester element. In the event that a flame stabilizes near or on the flame arrester element, a sudden increase in temperature will be detected by the temperature sensor and an emergency system (such as inerting, shut-off valves) must be activated to stop continuation of the combustion process. This activation process must occur within $0.5 \cdot t_{BT}$. t_{BT} is the burning time and specified on the flame arrester nameplate.

Elmac in-line deflagration flame arresters passed the tests that are in accordance with EN ISO 16852. EU Type examination certificates are available upon request.

Where stabilized burning near or on the flame arrester element is possible, a short time burn proof of deflagration flame arrester is required. In this case, one or two temperature sensors shall be installed against short time burning from one side or both sides. If only one temperature sensor is installed, it must be installed on the unprotected side of the flame arrester (i.e., the side from which a flame is expected).

Rev.	Description	Issued By	Date
6	Scan QR code added and Elmac logo updated.	D. Greenough	29.06.2021
5	Fifth Issue (format updated, and additional cautions added relating to installation).	O. Tuncer	28.09.2017
4	Fourth Issue (changes to ATEX Directive from 94/9/EC to 2014/34/EU).	O. Tuncer	03.09.2016
3	Third Issue (instruction added regarding threaded instruments and ports).	O. Tuncer	03.09.2015
2	Second Issue (element removal instructions incorporated).	O. Tuncer	13.01.2015
1	First Issue.	O. Tuncer	25.07.2014

Description: Installation & Maintenance Instructions for In-Line Deflagration Flame Arresters (ATEX)		 Elmac[®] Technologies Elmac Technologies Limited, Coast Road, Greenfield, Flintshire, CH8 9DP United Kingdom	
Drawn By: Ozkan Tuncer	Date: 02.07.2014		
Checked By: D. Greenough	Date: 29.06.2021	Document No. ELN-00085 Page 2 of 11	
Tel: +44 (0) 1352 717 555	The information contained herein is confidential and is the property of Elmac Technologies Ltd. The information is issued on the understanding that no part thereof be disclosed to a third party without written consent of Elmac Technologies Ltd.		Revision 6
Fax: +44 (0) 1352 717 642			
E-Mail : sales@elmactech.com			
Web: http://www.elmactechnologies.com			

Elmac Technologies Limited - Operating Instructions

Requirements to EN ISO 16852, ATEX Directive 2014/34/EU



Please register your product with Elmac Technologies to receive exclusive discounts on future spares orders. Scan QR code or visit <https://elmactechnologies.com/services/>

GENERAL PARTS LIST FOR FLAME ARRESTER UNITS

Part No.	Description	Part No.	Description
1	Connection Flange	11a	Earthing Cable
2	Reducer	11b	Crimping Cable Lug
3	Element Flange	11c	M6 Hex Head Screw
4	Element Gasket	11d	M6 Hex Head Nut
5	Studding	12a	Element Housing – Pipe
6	Hex Head Nuts	12b	Element Housing – Lifting Lugs
7	Standard Washers	12c	Element Housing – TOP Ring
8	Flame Arrestor Body Lifting Lugs	12d	Element Housing – BOTTOM Ring
9	Jacking Nuts	12e	Crimped Ribbon Core Element
10	Element Centering Ring	12f	Hex Socket Head Screw

Refer to Figure 2 – Section View on typical In-Line Flame Arrestor Assembly.

Notes:

- Part No. 1, 2 & 3 will become one single item in cast version.
- Part No. 2 – Concentric version shown within figure 2, Eccentric version available.
- Part No. 12a to 12f referred to as element assembly within the rest of this document.
- Part No. 12e – Number of elements may vary depending on the operation pressure and explosion group.
- Temperature sensors are required on short time burn arresters only (refer to typical layout of “Short Time Burn” flame arrester). If stabilised burning may occur on both sides, two temperature sensors are required to form bi-directional flame arrester for short time burning. Bi-directional units with two temperature sensors are available upon request.

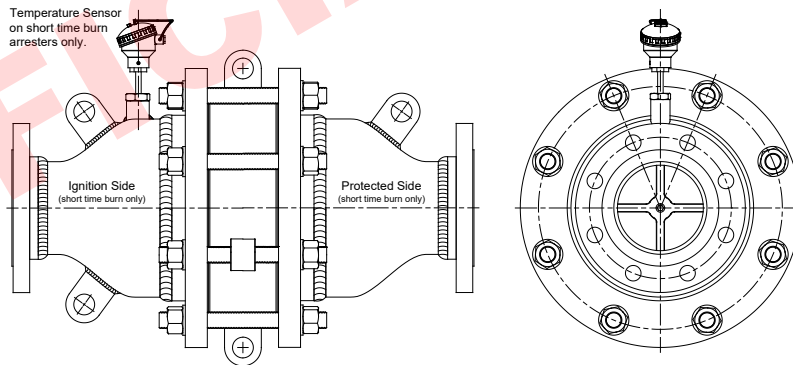

Typical layout of “Short Time Burn” flame arrester

6	Scan QR code added and Elmac logo updated.	D. Greenough	29.06.2021
5	Fifth Issue (format updated, and additional cautions added relating to installation).	O. Tuncer	28.09.2017
4	Fourth Issue (changes to ATEX Directive from 94/9/EC to 2014/34/EU).	O. Tuncer	03.09.2016
3	Third Issue (instruction added regarding threaded instruments and ports).	O. Tuncer	03.09.2015
2	Second Issue (element removal instructions incorporated).	O. Tuncer	13.01.2015
1	First Issue.	O. Tuncer	25.07.2014
Rev.	Description	Issued By	Date

Description:

Installation & Maintenance Instructions for In-Line Deflagration Flame Arresters (ATEX)

Drawn By: Ozkan Tuncer

Date: 02.07.2014

Checked By: D. Greenough

Date: 29.06.2021

Tel: +44 (0) 1352 717 555

Fax: +44 (0) 1352 717 642

E-Mail : sales@elmactech.com

Web: <http://www.elmactechnologies.com>

The information contained herein is confidential and is the property of Elmac Technologies Ltd. The information is issued on the understanding that no part thereof be disclosed to a third party without written consent of Elmac Technologies Ltd.



Elmac Technologies Limited, Coast Road, Greenfield, Flintshire, CH8 9DP United Kingdom

Document No.
ELN-00085
Page 3 of 11

Revision
6

Elmac Technologies Limited - Operating Instructions

Requirements to EN ISO 16852, ATEX Directive 2014/34/EU



Please register your product with Elmac Technologies to receive exclusive discounts on future spares orders. Scan QR code or visit <https://elmactechnologies.com/services/>

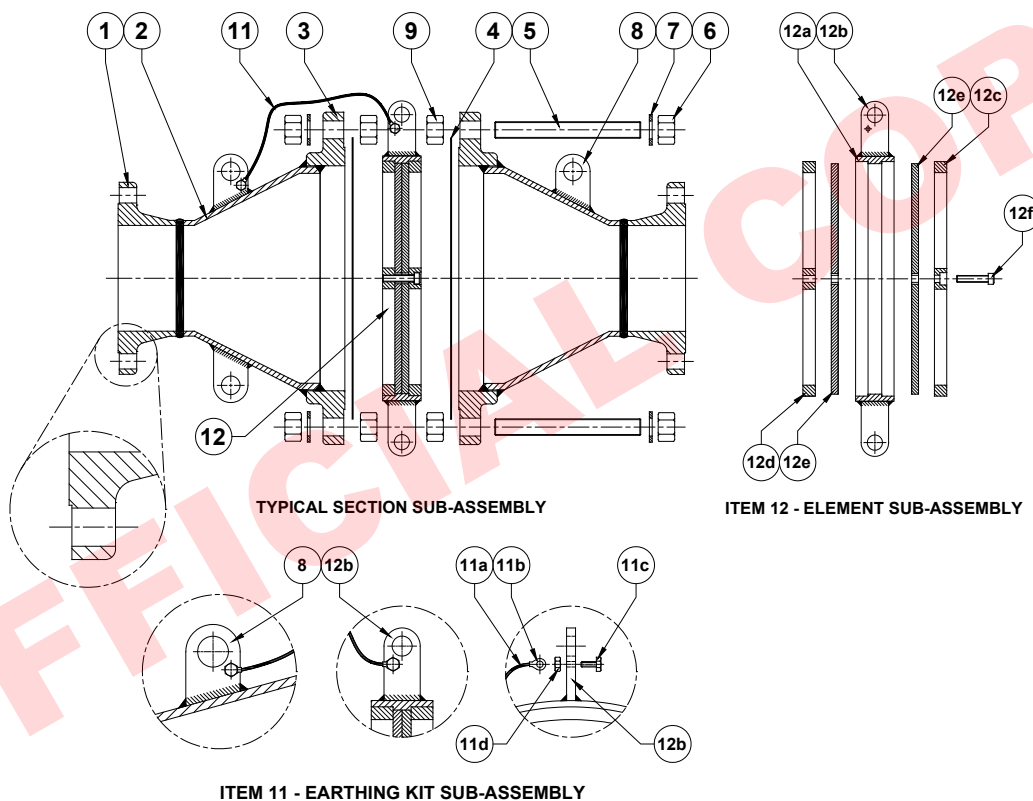
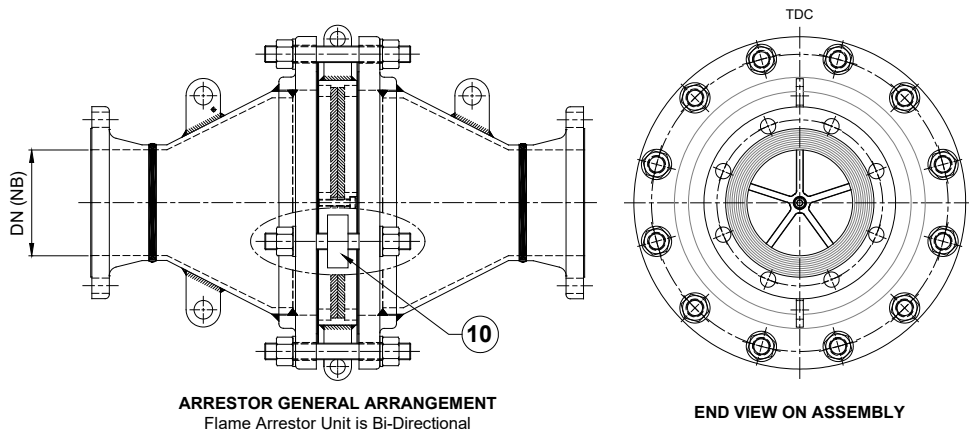



Figure 2 – Typical Section View on In-Line Flame Arrestor Assembly

Rev.	Description	Issued By	Date
6	Scan QR code added and Elmac logo updated.	D. Greenough	29.06.2021
5	Fifth Issue (format updated, and additional cautions added relating to installation).	O. Tuncer	28.09.2017
4	Fourth Issue (changes to ATEX Directive from 94/9/EC to 2014/34/EU).	O. Tuncer	03.09.2016
3	Third Issue (instruction added regarding threaded instruments and ports).	O. Tuncer	03.09.2015
2	Second Issue (element removal instructions incorporated).	O. Tuncer	13.01.2015
1	First Issue.	O. Tuncer	25.07.2014

Description: Installation & Maintenance Instructions for In-Line Deflagration Flame Arresters (ATEX)		 Elmac Technologies Elmac Technologies Limited, Coast Road, Greenfield, Flintshire, CH8 9DP United Kingdom	
Drawn By: Ozkan Tuncer	Date: 02.07.2014		
Checked By: D. Greenough	Date: 29.06.2021	Document No. ELN-00085 Page 4 of 11	Revision 6
Tel: +44 (0) 1352 717 555	The information contained herein is confidential and is the property of Elmac Technologies Ltd. The information is issued on the understanding that no part thereof be disclosed to a third party without written consent of Elmac Technologies Ltd.		
Fax: +44 (0) 1352 717 642			
E-Mail : sales@elmactech.com			
Web: http://www.elmactechnologies.com			

Elmac Technologies Limited - Operating Instructions

Requirements to EN ISO 16852, ATEX Directive 2014/34/EU



Please register your product with Elmac Technologies to receive exclusive discounts on future spares orders. Scan QR code or visit <https://elmactechnologies.com/services/>

INSTALLATION

1. Always refer to Figure 2 of this document and the information on the flame arrester nameplates when installing a flame arrester.
2. It is essential that Elmac in-line deflagration flame arresters are only used in the application and with the explosion group for which they were supplied (as stated within our written quotation). In particular, where a maximum distance for the location of a flame arrester from a potential ignition source has been specified in the quotation, then it is imperative that this distance is not exceeded on installation. The ratio of the pipe length between the potential ignition source and the flame arrester to the pipe diameter must not exceed 50:1 for explosion groups IIA up to IIB3 and 30:1 for explosion groups IIB and IIC, and the value specified on the nameplate/quotation (i.e. the tested ratio). At least 10% of the cross-sectional area of the pipe shall be open at the potential ignition source. Materials of construction must be compatible with the gas mixtures and the environment in which the unit is to operate. This is particularly important if the flame arrester is to be used in corrosive applications. Contact the Elmac technical sales department for advice.
3. For in-line deflagration flame arresters correct positioning of the flame arrester is vital. It is determined not only by the configuration of the associated pipe work, but also by the volatility of the gas mixture passing through. As a basic principle an in-line flame arrester should be located as close to the potential source of ignition as possible. The end users are required to make sure the inline deflagration flame arrester to be installed is suitable for the application, i.e., to check the explosion group, L/D, and operating pressure and temperature on the nameplate or on the quotation. In the event of any query please contact the Elmac technical sales department for advice.
4. Always ensure that the fixings available on the pipe work (e.g. flange type, screw thread) are compatible with those on the flame arrester. For flange fixings, use the correct fasteners and gaskets for the flange size and type. Always use the correct washers as to prevent damage caused by bolt heads and nuts on tightening up. Gaskets should be capable of withstanding the same temperatures and pressures as the flame arresters being operated.
5. In-line deflagration flame arresters should be positioned so that the element assembly is accessible for removal. Models with drain plugs fitted are designed for horizontal applications.

Rev.	Description	Issued By	Date
6	Scan QR code added and Elmac logo updated.	D. Greenough	29.06.2021
5	Fifth Issue (format updated, and additional cautions added relating to installation).	O. Tuncer	28.09.2017
4	Fourth Issue (changes to ATEX Directive from 94/9/EC to 2014/34/EU).	O. Tuncer	03.09.2016
3	Third Issue (instruction added regarding threaded instruments and ports).	O. Tuncer	03.09.2015
2	Second Issue (element removal instructions incorporated).	O. Tuncer	13.01.2015
1	First Issue.	O. Tuncer	25.07.2014

Description: Installation & Maintenance Instructions for In-Line Deflagration Flame Arresters (ATEX)		 Elmac[®] Technologies Elmac Technologies Limited, Coast Road, Greenfield, Flintshire, CH8 9DP United Kingdom	
Drawn By: Ozkan Tuncer	Date: 02.07.2014		
Checked By: D. Greenough	Date: 29.06.2021	Document No. ELN-00085 Page 5 of 11	Revision 6
Tel: +44 (0) 1352 717 555	The information contained herein is confidential and is the property of Elmac Technologies Ltd. The information is issued on the understanding that no part thereof be disclosed to a third party without written consent of Elmac Technologies Ltd.		
Fax: +44 (0) 1352 717 642			
E-Mail : sales@elmactech.com			
Web: http://www.elmactechnologies.com			

Elmac Technologies Limited - Operating Instructions

Requirements to EN ISO 16852, ATEX Directive 2014/34/EU



Please register your product with Elmac Technologies to receive exclusive discounts on future spares orders. Scan QR code or visit <https://elmactechnologies.com/services/>

- Important Note: Threaded instruments and ports must comply to IEC 60079-1 according to Section 6.3 of EN ISO 16852:2010**
- Caution: Always ensure that the system is at atmospheric pressure and there is no hazardous gas present including any flammable gas/vapour that could flash when either installing or maintaining a unit.**
- The short time burn proof of in-line deflagration flame arresters can be identified by the letter 'b' and burn time duration next to the 'Burn Rating Group - BC' in the flame arrester label.**
- The short time burn flame arresters are equipped with at least one integrated temperature sensor. The temperature sensor can detect a flame stabilization near or on the flame arrester element. Once detecting the flame, the temperature sensor will produce a signal to activate an emergency safety system to extinguish the flame via such as shut off the gas flow (by-passing, sufficient diluting or inerting are measures equivalent to stopping the flow) within $0.5 \cdot t_{BT}$.**
- Short time burn arresters with one temperature sensor are uni-directional. Extra care should be taken to ensure that the temperature sensor is located on the un-protected (ignition) side of the pipeline.**

MAINTENANCE

- Maintenance and inspection are the responsibility of the customer and not of Elmac Technologies Limited.**
- Flame arrestors should be inspected on a regular basis to ensure that no build-up of solids or liquids occurs in the elements as this will adversely affect the performance of the unit during process flow conditions. The maintenance interval must be determined by the user and is governed by the amount and type of particulates in the system in which the unit is installed. The user should check the elements in the first few months of operation to find out how quickly particulates accumulate. After cleaning, the elements should be thoroughly inspected for damage and if damaged they must be replaced. Flame arrestors should also be inspected if a flashback is known or suspected to have occurred.
- The element assembly will have to be removed from the flame arrester for inspection. For in-line flame arrestors provided with a jacking arrangement, the jacking screws and/or nuts are solely for splitting flanges slightly to remove the element assembly.

Rev.	Description	Issued By	Date
6	Scan QR code added and Elmac logo updated.	D. Greenough	29.06.2021
5	Fifth Issue (format updated, and additional cautions added relating to installation).	O. Tuncer	28.09.2017
4	Fourth Issue (changes to ATEX Directive from 94/9/EC to 2014/34/EU).	O. Tuncer	03.09.2016
3	Third Issue (instruction added regarding threaded instruments and ports).	O. Tuncer	03.09.2015
2	Second Issue (element removal instructions incorporated).	O. Tuncer	13.01.2015
1	First Issue.	O. Tuncer	25.07.2014

Description: Installation & Maintenance Instructions for In-Line Deflagration Flame Arresters (ATEX)		 Elmac[®] Technologies Elmac Technologies Limited, Coast Road, Greenfield, Flintshire, CH8 9DP United Kingdom	
Drawn By: Ozkan Tuncer	Date: 02.07.2014	Document No. ELN-00085 Page 6 of 11	Revision 6
Checked By: D. Greenough	Date: 29.06.2021		
Tel: +44 (0) 1352 717 555	The information contained herein is confidential and is the property of Elmac Technologies Ltd. The information is issued on the understanding that no part thereof be disclosed to a third party without written consent of Elmac Technologies Ltd.		
Fax: +44 (0) 1352 717 642			
E-Mail : sales@elmactech.com			
Web: http://www.elmactechnologies.com			

Elmac Technologies Limited - Operating Instructions

Requirements to EN ISO 16852, ATEX Directive 2014/34/EU



Please register your product with Elmac Technologies to receive exclusive discounts on future spares orders. Scan QR code or visit <https://elmactechnologies.com/services/>

They are not for lifting large weights of pipe work. **Element assemblies can be heavy and will require adequate equipment and manpower to prevent injury when handling.**

Refer to Figure 5 for additional element assembly removal instructions.

4. Each crimped ribbon element bank (part number 12e) can be removed from element housing for inspection and cleaning. Care should be taken during the removal process to avoid damage to the crimped ribbon element. Also, the element should always be supported at least on one side if the compressed air/steam is to be blown through.
5. Elements may be cleaned with any suitable solvent followed by a blow through with compressed air. Steam cleaning may also be effective. If the arrestor element cannot be cleaned satisfactorily, it must be replaced. Flame arrestors of a crimped metal ribbon construction will lose efficiency under process flow conditions if the edges of the metal ribbon are damaged or folded over during cleaning or normal operation. It is advisable to hold spares in stock in site stores. Always use Elmac replacement parts and quote the flame arrestor serial number when ordering spare elements or other parts.
6. Elements have inclined channels and are wound in a way to create right-hand and left-hand channels. Each element with left-hand channels is followed by an element with right-hand channels. This element arrangement order is critical for the proper functioning of the arrestor. Crimped ribbon elements are marked on the outer edge with the direction of the channels and serial number of the element. During removal this order of the elements should be noted, and the same order must be followed during assembly. Refer to Figure 3 – Crimped Ribbon Element Arrangement.

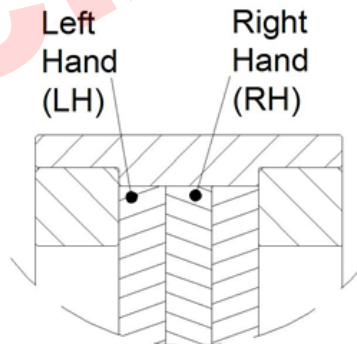



Figure 3 – Crimped Ribbon Element Arrangement for In-Line Flame Arrestors

Rev.	Description	Issued By	Date
6	Scan QR code added and Elmac logo updated.	D. Greenough	29.06.2021
5	Fifth Issue (format updated, and additional cautions added relating to installation).	O. Tuncer	28.09.2017
4	Fourth Issue (changes to ATEX Directive from 94/9/EC to 2014/34/EU).	O. Tuncer	03.09.2016
3	Third Issue (instruction added regarding threaded instruments and ports).	O. Tuncer	03.09.2015
2	Second Issue (element removal instructions incorporated).	O. Tuncer	13.01.2015
1	First Issue.	O. Tuncer	25.07.2014

Description: Installation & Maintenance Instructions for In-Line Deflagration Flame Arrestors (ATEX)		 Elmac Technologies Limited, Coast Road, Greenfield, Flintshire, CH8 9DP United Kingdom	
Drawn By: Ozkan Tuncer	Date: 02.07.2014		
Checked By: D. Greenough	Date: 29.06.2021	Document No. ELN-00085 Page 7 of 11	
Tel: +44 (0) 1352 717 555	The information contained herein is confidential and is the property of Elmac Technologies Ltd. The information is issued on the understanding that no part thereof be disclosed to a third party without written consent of Elmac Technologies Ltd.		Revision 6
Fax: +44 (0) 1352 717 642			
E-Mail : sales@elmactech.com			
Web: http://www.elmactechnologies.com			

Elmac Technologies Limited - Operating Instructions

Requirements to EN ISO 16852, ATEX Directive 2014/34/EU



Please register your product with Elmac Technologies to receive exclusive discounts on future spares orders. Scan QR code or visit <https://elmactechnologies.com/services/>

7. Support bars on each element support ring (part number 12c and 12d) must be aligned during assembly. Failure to do this will result in a drop in free flow area and unit performance. Refer to Figure 4 – Element Ring Support Bar Alignment.

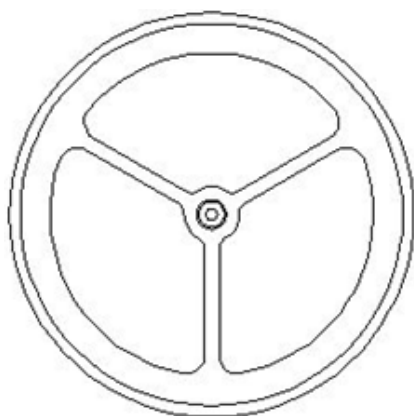

Correct Installation
Element Support Bars Aligned

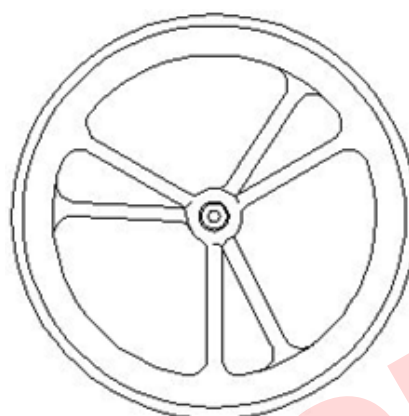

In-Correct Installation
Element Ring Support Bars Miss-Aligned

Figure 4 – Element Ring Support Bar Alignment

8. Crimped ribbon elements may be replaced with a spare element on site only for element assembly sizes up to and including DN300. Element assemblies above DN300 must be sent to Elmac for fitting of new set of crimped ribbon elements. Therefore, **customers are advised to keep an extra element assembly on-site.**
9. Removal and replacement of elements should be undertaken with care and all washers and fasteners must be replaced exactly as originally fitted to prevent leakage of gases and provide unrestricted gas flow through the unit. **To ensure a gas tight seal, element assembly gaskets (part number 4) should be replaced every time the flame arrester body is loosened or dismantled for element maintenance and must be replaced exactly as originally fitted.**

Always use the new gaskets supplied with spare element assemblies and ensure that mating faces are clean. Some Elmac elements are designed to fit several types of flange so it is important to centralize the element between the flanges before tightening up fasteners. Fasteners should be well lubricated with general purpose grease and tightened to the torque settings. The torque settings and the torquing sequence are given below for reference.

Rev.	Description	Issued By	Date
6	Scan QR code added and Elmac logo updated.	D. Greenough	29.06.2021
5	Fifth Issue (format updated, and additional cautions added relating to installation).	O. Tuncer	28.09.2017
4	Fourth Issue (changes to ATEX Directive from 94/9/EC to 2014/34/EU).	O. Tuncer	03.09.2016
3	Third Issue (instruction added regarding threaded instruments and ports).	O. Tuncer	03.09.2015
2	Second Issue (element removal instructions incorporated).	O. Tuncer	13.01.2015
1	First Issue.	O. Tuncer	25.07.2014

Description: Installation & Maintenance Instructions for In-Line Deflagration Flame Arresters (ATEX)		 Elmac Technologies Limited, Coast Road, Greenfield, Flintshire, CH8 9DP United Kingdom	
Drawn By: Ozkan Tuncer	Date: 02.07.2014		
Checked By: D. Greenough	Date: 29.06.2021	Document No. ELN-00085 Page 8 of 11	Revision 6
Tel: +44 (0) 1352 717 555	The information contained herein is confidential and is the property of Elmac Technologies Ltd. The information is issued on the understanding that no part thereof be disclosed to a third party without written consent of Elmac Technologies Ltd.		
Fax: +44 (0) 1352 717 642			
E-Mail : sales@elmactech.com			
Web: http://www.elmactechnologies.com			

Elmac Technologies Limited - Operating Instructions

Requirements to EN ISO 16852, ATEX Directive 2014/34/EU



Please register your product with Elmac Technologies to receive exclusive discounts on future spares orders. Scan QR code or visit <https://elmactechnologies.com/services/>

Bolt Size	Socket / Spanner Size (mm)	Torque settings - Nm (lbf.ft)			
		Step 1	Step 2	Step 3	Full Torque
M12	19	40Nm (30lbf.ft)	N/A.	N/A.	70Nm (51lbf.ft)
M16	24	50Nm (37lbf.ft)	N/A.	N/A.	100Nm (73lbf.ft)
M20	30	50Nm (37lbf.ft)	100Nm (73lbf.ft)	N/A.	140Nm (103lbf.ft)
M24	36	50Nm (37lbf.ft)	100Nm (73lbf.ft)	150Nm (110lbf.ft)	200Nm (147lbf.ft)
M27	41	50Nm (37lbf.ft)	100Nm (73lbf.ft)	150Nm (110lbf.ft)	200Nm (147lbf.ft)
M30	46	50Nm (37lbf.ft)	110Nm (81lbf.ft)	170Nm (125lbf.ft)	220Nm (162lbf.ft)
M33	50	70Nm (51lbf.ft)	140Nm (103lbf.ft)	210Nm (154lbf.ft)	280Nm (206lbf.ft)
M36	55	70Nm (51lbf.ft)	160Nm (118lbf.ft)	240Nm (177lbf.ft)	300Nm (221lbf.ft)

Note: Excessive or uneven torquing can cause permanent damage to gaskets and housings.

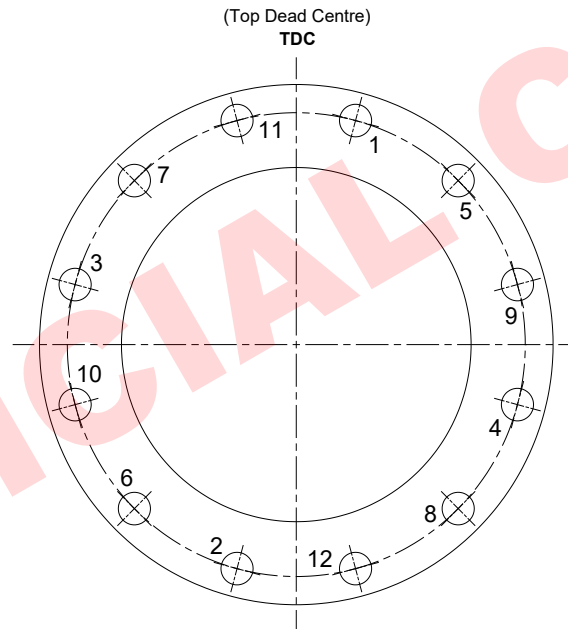

Torquing Sequence

Base torque on the above sketch. However, allow for flanges with different number of bolt holes

6	Scan QR code added and Elmac logo updated.	D. Greenough	29.06.2021
5	Fifth Issue (format updated, and additional cautions added relating to installation).	O. Tuncer	28.09.2017
4	Fourth Issue (changes to ATEX Directive from 94/9/EC to 2014/34/EU).	O. Tuncer	03.09.2016
3	Third Issue (instruction added regarding threaded instruments and ports).	O. Tuncer	03.09.2015
2	Second Issue (element removal instructions incorporated).	O. Tuncer	13.01.2015
1	First Issue.	O. Tuncer	25.07.2014
Rev.	Description	Issued By	Date

Description:

Installation & Maintenance Instructions for In-Line Deflagration Flame Arresters (ATEX)

Drawn By: Ozkan Tuncer

Date: 02.07.2014

Checked By: D. Greenough

Date: 29.06.2021

Tel: +44 (0) 1352 717 555

Fax: +44 (0) 1352 717 642

E-Mail : sales@elmactech.com

Web: <http://www.elmactechnologies.com>

The information contained herein is confidential and is the property of Elmac Technologies Ltd. The information is issued on the understanding that no part thereof be disclosed to a third party without written consent of Elmac Technologies Ltd.



Elmac[®]
Technologies

Elmac Technologies Limited, Coast Road,
Greenfield, Flintshire, CH8 9DP United Kingdom

Document No.
ELN-00085
Page 9 of 11

Revision
6

Elmac Technologies Limited - Operating Instructions

Requirements to EN ISO 16852, ATEX Directive 2014/34/EU



Please register your product with Elmac Technologies to receive exclusive discounts on future spares orders. Scan QR code or visit <https://elmactechnologies.com/services/>

10. Installations that require frequent maintenance and minimum downtime. It is recommended that the user purchases a spare element assembly and several spare element gaskets. This spare element assembly can be installed immediately, and the dirty element assembly can then be cleaned and stored as a spare ready for the next maintenance interval.
11. The temperature sensors (including related connectors and cables, if present) must be checked against any damage or wearing during flame arrester maintenance. If any damage is observed, the item must be replaced. Customers should contact Elmac Technologies for replacement sensors.
12. The flame arrester element must be replaced after a flashback or short time burn occurs on the flame arrester element.

IN THE EVENT OF ANY QUERY PLEASE CONTACT OUR TECHNICAL SALES DEPARTMENT

ELEMENT ASSEMBLY REMOVAL INSTRUCTIONS

1. Remove earthing cable.
2. Loosen and remove all nuts, washers and threaded bars located above the element centre axis.
3. Loosen the remaining nuts in the bottom half of the element flange.
4. By rotating the jacking nuts clockwise, jack the half bodies apart to create a gap.
5. Remove element assembly.
6. Always use appropriate lifting devices during element assembly removal.

Rev.	Description	Issued By	Date
6	Scan QR code added and Elmac logo updated.	D. Greenough	29.06.2021
5	Fifth Issue (format updated, and additional cautions added relating to installation).	O. Tuncer	28.09.2017
4	Fourth Issue (changes to ATEX Directive from 94/9/EC to 2014/34/EU).	O. Tuncer	03.09.2016
3	Third Issue (instruction added regarding threaded instruments and ports).	O. Tuncer	03.09.2015
2	Second Issue (element removal instructions incorporated).	O. Tuncer	13.01.2015
1	First Issue.	O. Tuncer	25.07.2014

Description: Installation & Maintenance Instructions for In-Line Deflagration Flame Arresters (ATEX)		 Elmac Technologies Elmac Technologies Limited, Coast Road, Greenfield, Flintshire, CH8 9DP United Kingdom		
Drawn By: Ozkan Tuncer	Date: 02.07.2014	Document No. ELN-00085 Page 10 of 11		
Checked By: D. Greenough	Date: 29.06.2021			Revision 6
Tel: +44 (0) 1352 717 555	The information contained herein is confidential and is the property of Elmac Technologies Ltd. The information is issued on the understanding that no part thereof be disclosed to a third party without written consent of Elmac Technologies Ltd.			
Fax: +44 (0) 1352 717 642				
E-Mail : sales@elmactech.com				
Web: http://www.elmactechnologies.com				

Elmac Technologies Limited - Operating Instructions

Requirements to EN ISO 16852, ATEX Directive 2014/34/EU



Please register your product with Elmac Technologies to receive exclusive discounts on future spares orders. Scan QR code or visit <https://elmactechnologies.com/services/>

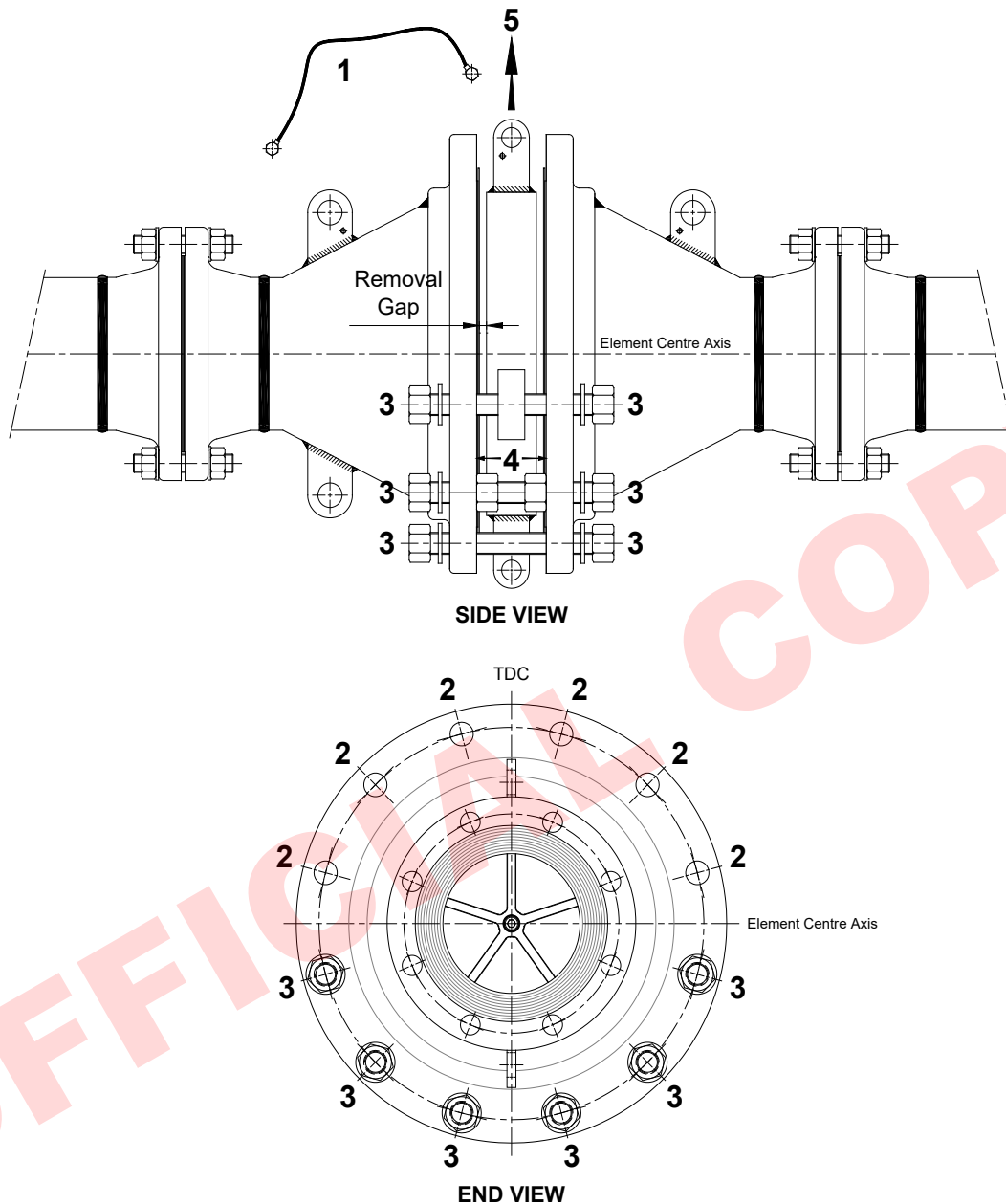



Figure 5 – Typical Element Assembly Removal Instructions

6	Scan QR code added and Elmac logo updated.	D. Greenough	29.06.2021
5	Fifth Issue (format updated, and additional cautions added relating to installation).	O. Tuncer	28.09.2017
4	Fourth Issue (changes to ATEX Directive from 94/9/EC to 2014/34/EU).	O. Tuncer	03.09.2016
3	Third Issue (instruction added regarding threaded instruments and ports).	O. Tuncer	03.09.2015
2	Second Issue (element removal instructions incorporated).	O. Tuncer	13.01.2015
1	First Issue.	O. Tuncer	25.07.2014
Rev.	Description	Issued By	Date

Description: Installation & Maintenance Instructions for In-Line Deflagration Flame Arresters (ATEX)		 Elmac Technologies Limited, Coast Road, Greenfield, Flintshire, CH8 9DP United Kingdom	
Drawn By: Ozkan Tuncer	Date: 02.07.2014		
Checked By: D. Greenough	Date: 29.06.2021	Document No. ELN-00085 Page 11 of 11	Revision 6
Tel: +44 (0) 1352 717 555	The information contained herein is confidential and is the property of Elmac Technologies Ltd. The information is issued on the understanding that no part thereof be disclosed to a third party without written consent of Elmac Technologies Ltd.		
Fax: +44 (0) 1352 717 642			
E-Mail : sales@elmactech.com			
Web: http://www.elmactechnologies.com			